



# V9261F Datasheet

Copyright © 2021 Vango Technologies, Inc.

This document contains information that is proprietary to Vango Technologies, Inc.

Unauthorized reproduction of this information in whole or in part is strictly prohibited.

## Revision History

Date	Version	Description
2015.04.28	0.1	Initial release
2015.05.08	0.2	English grammar review
2015.11.03	0.3	<ul style="list-style-type: none"> <li>Updated register "0x0180, SysCtrl" (bit28 and bit[23:21]) and "0x0183" (bit[7:5]) in Table 9-4.</li> <li>Added CF output protection function in power-down state.</li> <li>Added ref power-down protection function.</li> </ul>
2016.05.19	0.4	<ul style="list-style-type: none"> <li>Updated 7.2 Baud Rate Configuration</li> </ul>
2016.10.31	0.5	<ul style="list-style-type: none"> <li>Removed INT pin related descriptions</li> </ul>
2018.03.12	5.0	<ul style="list-style-type: none"> <li>In order to obtain the best metering performance and temperature performance during normal metering, Bandgap Circuit must be configured according to the calculated result. The calculation method, please refer to Bandgap Circuit chapter.</li> </ul>
2018.05.31	5.1	<ul style="list-style-type: none"> <li>Modify the formula of Phase Compensation.</li> <li>HPF cannot be bypassed in M channel, modify figure of Energy Metering.</li> </ul>
2019.04.09	7.0	<ul style="list-style-type: none"> <li>Modify the storage temperature to -55~150°C</li> <li>Modify Absolute Maximum Ratings</li> <li>Modify Calibration Step</li> </ul>
2021.04.19	7.1	<ul style="list-style-type: none"> <li>Update IEC Standard</li> </ul>

# Features

- 5.0 V power supply, wide range:  
3.0 V ~ 5.5 V
- Internal reference: 1.188 V (Typical drift  
10 ppm/°C)
- Typical power consumption in normal  
operation: 1.9 mA
- Three independent oversampling  $\Sigma/\Delta$   
ADCs: One for voltage, one for current,  
and one for multifunctional measurements
- Support UART communication interface,  
baud rate: 4800 bps
- Crystal frequency: 6.5536 MHz or  
3.2768 MHz
- Highly metering accuracy:
  - ✓ < 0.1% error in total/fundamental  
active energy over a dynamic range of  
5000:1
  - ✓ < 0.1% error in total/fundamental  
reactive energy over a dynamic range  
of 3000:1
  - ✓ Supporting the requirements of IEC  
62053-21:2020/ IEC 62053-22:2020  
and IEC 62053-23:2020.
- Supporting various measurements
  - ✓ DC components of voltage and  
current signals
  - ✓ Total/Fundamental  
raw/instantaneous/average  
current and voltage RMS
  - ✓ Total/Fundamental  
raw/instantaneous/average active  
and reactive power
  - ✓ Positive/Negative energy,  
selectable active/reactive power
  - ✓ Line frequency and temperature
- Supporting software calibration
- Supporting current detection
- Supporting programmable no-load  
detection threshold
- Accelerating meter calibration when low  
signal is applied
- CF signals output
- Current input: Current transformer and  
shunt resistor
- Operating temperature: -40°C ~ +85°C
- Storage temperature: -55°C ~ +150°C
- Package: 16-SOP

Vangotech

# Specifications

All maximum/minimum specifications apply over the entire recommended operation range (T = -40°C ~ +85°C, VDD5 = 5.0V ±10%) unless otherwise noted. All typical specifications are at T = 25°C, VDD5 = 5.0 V, unless otherwise noted.

Parameter	Min.	Typ.	Max.	Unit	Remark
<b>Analog Input</b>					
Maximum Signal Level			±200	mV	Peak value
<b>ADC</b>					
DC Offset			10	mV	
Resolution		23		Bit	Sign bit is included.
Bandwidth (-3dB)		1.6		kHz	
<b>On-chip Reference</b>					
Reference Error	-18		18	mV	
Power Supply Rejection Ratio		80		dB	
Temperature Coefficient		10	50	ppm/°C	
Output Voltage		1.188		V	
<b>Power Supply</b>					
VDD5	3.0	5.0	5.5	V	
<b>AVCC</b>					
Voltage	2.8	3.3	3.5	V	VDD5 ≥ 4V, I <sub>L33</sub> = 16mA
Current			30	mA	
<b>Power-Down Detection Threshold</b>		2.8		V	Error: ±5%
<b>Digital Power Supply (DVCC)</b>					
Voltage		1.8		V	Programmable. Error: ±10%
Current			35	mA	
<b>POR Detection Threshold</b>		1.45		V	Error: ±10%
<b>Pin "CTI"/ "CTO"</b>					
Crystal Frequency		3.2768 6.5536		MHz	

Parameter	Min.	Typ.	Max.	Unit	Remark
Equivalent Series Resistance (ESR)	30		100	Ω	For 6.5536-MHz crystal
	30		200	Ω	For 3.2768-MHz crystal
<b>Phase Error Between Channels</b>					
PF = 0.8 Capacitive		±0.05		Degree	
PF = 0.5 Inductive		±0.05		Degree	
<b>Total Active Energy Metering Error</b>		0.1		%	Dynamic Range 10000:1 @ 25°C
<b>Total Active Energy Metering Bandwidth</b>		1.6		kHz	
<b>Total Reactive Energy Metering Error</b>		0.1		%	Dynamic Range 5000:1 @ 25°C
<b>Total Reactive Energy Metering Bandwidth</b>		1.6		kHz	
<b>Fundamental Active Energy Metering Error</b>		0.1		%	Dynamic Range 10000:1 @ 25°C
<b>Fundamental Active Energy Metering Bandwidth</b>		65		Hz	
<b>Fundamental Reactive Energy Metering Error</b>		0.1		%	Dynamic Range 5000:1 @ 25°C
<b>Fundamental Reactive Energy Metering Bandwidth</b>		65		Hz	
<b>Total VRMS/s Metering Error</b>		1		%	Dynamic Range 1000:1 @ 25°C
<b>Total VRMS Metering Bandwidth</b>		1.6		kHz	
<b>Fundamental VRMS/s Metering Error</b>		1		%	Dynamic Range 5000:1 @ 25°C
<b>Fundamental VRMS Metering Bandwidth</b>		65		Hz	
<b>Total IRMS/s Metering Error</b>		1		%	Dynamic Range 1000:1 @ 25°C
<b>Total IRMS Metering Bandwidth</b>		1.6		kHz	

Parameter	Min.	Typ.	Max.	Unit	Remark
<b>Fundamental IRMS/s Metering Error</b>		1		%	Dynamic Range 5000:1 @ 25°C
<b>Fundamental IRMS Metering Bandwidth</b>		65		Hz	
<b>Current Detection Cycle</b>	15	25	30	ms	
<b>Frequency Measurement</b>					
Range	40		70	Hz	
Error		0.01		Hz	
<b>CF Pulse Output</b>					
Output Frequency			102.4	kHz	
Duty Cycle		50		%	When the pulse period is less than 160 ms
Active High Pulse Width		80		ms	
<b>Temperature Measurement</b>					
Range	-40		+85	°C	
Error		±2		°C	
<b>Logic Output</b>	<b>"TX"/"CF"</b>				
Output High Voltage, $V_{OH}$	1.7			V	Load of 8-mA current in a short time may not damage the chip, but load of 8-mA current for a long time may damage the chip.
$I_{SOURCE}$			8	mA	
Output Low Voltage, $V_{OL}$			0.7	V	
$I_{SINK}$			8	mA	
<b>Logic Input</b>	<b>"RX"</b>				
Input High Voltage, $V_{INH}$	2.0		3.6	V	
Input Low Voltage, $V_{INL}$	-0.3		0.7	V	
Input Current, $I_{IN}$			1	μA	
Input Capacitance, $C_{IN}$			20	pF	
<b>Baud Rate</b>		4800		bps	

# Absolute Maximum Ratings

Operating circumstance exceeding "**Absolute Maximum Ratings**" may cause the permanent damage to the device.

Parameters	Min.	Typ.	Max.	Unit	Description
Power Supply (VDD5)	-0.3		+8.0	V	To ground
Digital Power Supply (DVCC)	-0.3		+1.98	V	To ground
Analog Power Supply (AVCC)	-0.3		+3.6	V	To ground
Analog Input Voltage (IN/IP/UN/UP)	-0.3		+3.3	V	To ground
Operating Temperature	-40		+85	°C	
Storage Temperature	-55		+150	°C	

# Pin Descriptions

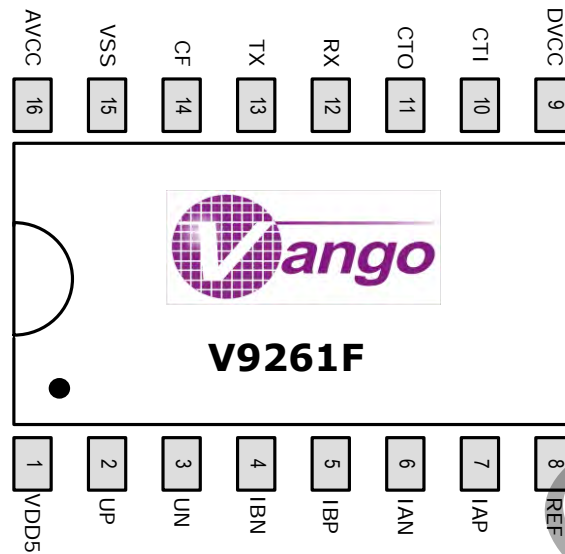

No.	Mnemonic	Type	Description
1	VDD5	Power	5.0-V power supply This pin must be decoupled to a $\geq 0.1\text{-}\mu\text{F}$ capacitor.
2	UP	Input	Positive input for Voltage Channel
3	UN	Input	Negative input for Voltage Channel
4	IBN	Input	Negative input for Current Channel B (IB)
5	IBP	Input	Positive input for Current Channel B (IB)
6	IAN	Input	Negative input for Current Channel A (IA)
7	IAP	Input	Positive input for Current Channel A (IA)
8	REF	Input/Output	On-chip reference This pin must be connected to a $1\text{-}\mu\text{F}$ capacitor, and then analog grounded.
9	DVCC	Power	Digital power output This pin must be connected to a parallel circuit combined by a $\geq 4.7\text{-}\mu\text{F}$ capacitor and $0.1\text{-}\mu\text{F}$ capacitor, and then grounded.
10	CTI	Input	Connect a 6.5536-MHz crystal around both pins.
11	CTO	Output	There is fixed load capacitance of 12 pF in the oscillation circuit. The requirement of the crystal oscillator: the load capacitance of crystal oscillator is 12PF, ESR<100 ohm.
12	RX	Input	UART Receiver data input Hold low logic for at least 64 ms to reset the chip

No.	Mnemonic	Type	Description
			In the Sleep Mode, a low-to-high transition (Holding low and high for at least 250 $\mu$ s respectively) on this pin can wake up the chip to get to the Current Detection Mode.
13	TX	Output	UART Transmitter data output
14	CF	Output	CF pulse output
15	VSS	Ground	Ground
16	AVCC	Output	3.3-V AVCC LDO output This pin must be decoupled to a $\geq 4.7\text{-}\mu\text{F}$ capacitor in parallel with a $0.1\text{-}\mu\text{F}$ capacitor, and then grounded.

Vangotech

# Functional Block Diagram

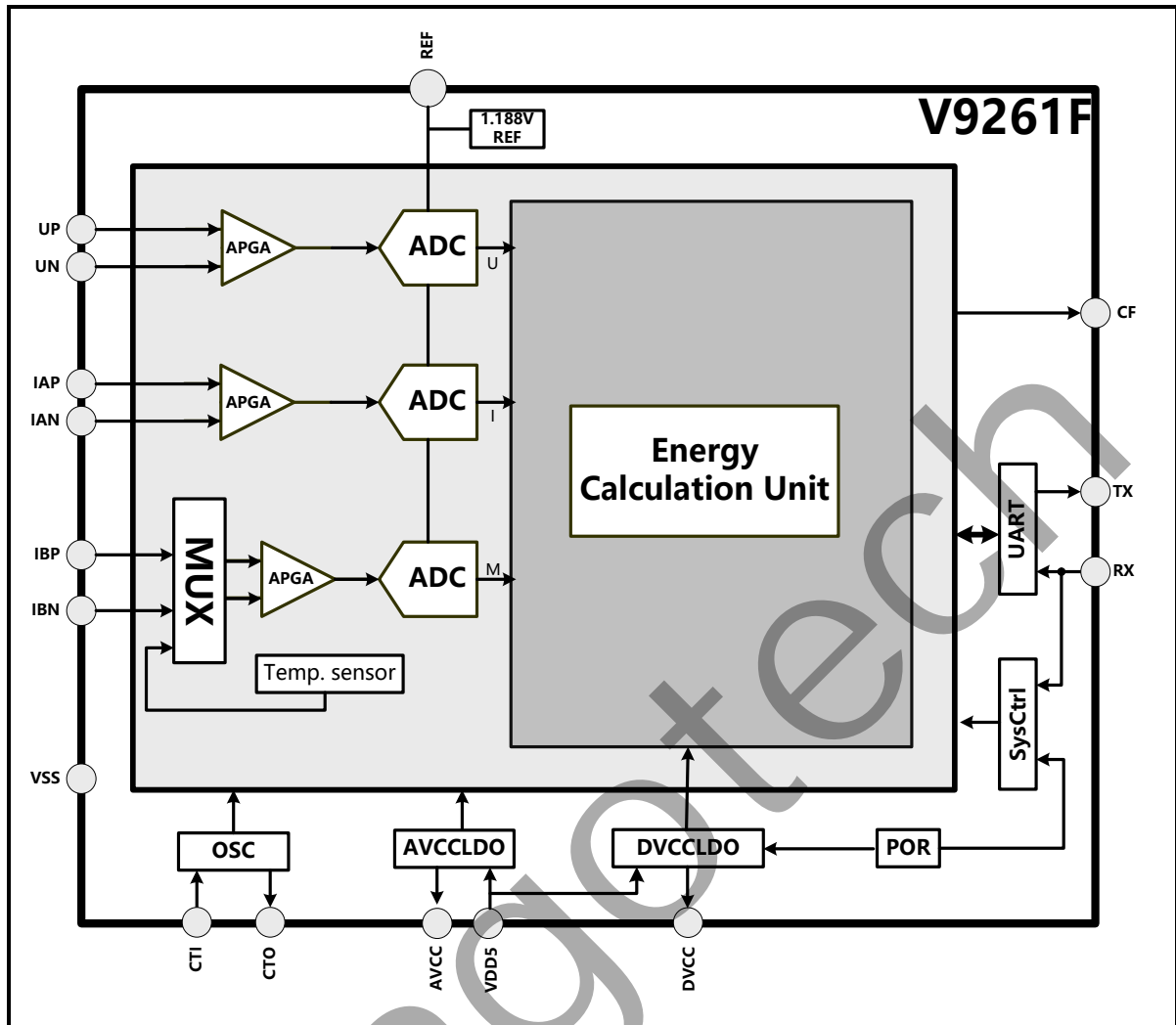

# Table of Contents

<b>Revision History</b> .....	<b>2</b>
<b>Features</b> .....	<b>3</b>
<b>Specifications</b> .....	<b>5</b>
<b>Absolute Maximum Ratings</b> .....	<b>8</b>
<b>Pin Descriptions</b> .....	<b>9</b>
<b>Functional Block Diagram</b> .....	<b>11</b>
<b>Table of Contents</b> .....	<b>12</b>
<b>Figure List</b> .....	<b>14</b>
<b>Table List</b> .....	<b>15</b>
<b>1. Reset</b> .....	<b>17</b>
1.1. Power-On Reset (POR) .....	17
1.2. RX Reset .....	17
1.3. Global Software Reset .....	18
1.4. Registers .....	19
<b>2. Clock</b> .....	<b>20</b>
2.1. Crystal Oscillation Circuit .....	20
2.2. 3.2-MHz RC Oscillator .....	21
2.3. 32-kHz RC Oscillator .....	22
2.4. Registers .....	22
<b>3. Operation Modes</b> .....	<b>26</b>
3.1. Metering Mode .....	27
3.2. Sleep Mode .....	28
3.3. Current Detection Mode .....	29
3.4. Power Dissipation .....	30
<b>4. Power Supply</b> .....	<b>33</b>
4.1. Power Supply Monitoring Circuit .....	33
4.2. Digital Power Supply .....	34
4.3. Registers .....	34
<b>5. Bandgap Circuit</b> .....	<b>36</b>
<b>6. Energy Metering</b> .....	<b>38</b>
6.1. Metering Clock ("MEACLK") .....	38
6.2. Analog Input .....	39
6.3. Analog-to-Digital Conversion .....	41
6.4. Phase Compensation .....	43
6.5. Digital Input and DC Removal .....	44
6.6. RMS Calculation .....	45
6.7. Power Calculation .....	47
6.8. Energy Accumulation and CF Pulse Output .....	49
6.9. No-Load Detection .....	51

6.10.	Line Frequency Measurement .....	51
6.11.	Measuring Various Signals in M Channel .....	52
6.12.	Calibration .....	55
6.12.1.	Registers for Meter Calibration .....	55
6.12.2.	Equations for Calibration .....	56
6.12.3.	Calibration Steps .....	58
<b>7.</b>	<b>UART Interface .....</b>	<b>61</b>
7.1.	Data Byte .....	61
7.2.	Baud Rate Configuration .....	61
7.3.	Communication Protocol .....	61
7.3.1.	Write Operation .....	63
7.3.2.	Read Operation .....	63
7.3.3.	Broadcast Communication .....	65
<b>8.</b>	<b>Interrupt .....</b>	<b>66</b>
8.1.	System Control Register Self-Checking Interrupt .....	66
8.2.	Configuration Verification Interrupt .....	66
8.3.	Zero-Crossing Interrupt .....	68
8.4.	Current Detection Interrupt .....	68
8.5.	Registers .....	69
<b>9.</b>	<b>Registers .....</b>	<b>72</b>
9.1.	Analog Control Registers .....	72
9.2.	System Control Register .....	78
9.3.	Metering Control Registers .....	81
9.4.	Data Registers .....	85
9.5.	Registers for Calibration .....	92
9.6.	Checksum Register .....	94
<b>10.</b>	<b>Outline Dimensions .....</b>	<b>96</b>

# Figure List

Figure 1-1 Timing of POR .....	17
Figure 1-2 Timing of RX Reset .....	18
Figure 1-3 Timing of Global Software Reset.....	19
Figure 2-1 Clock Generation .....	20
Figure 3-1 Operating Modes.....	27
Figure 4-1 Power Supply Architecture.....	33
Figure 4-2 Power-Down Interrupt.....	34
Figure 6-1 Signal Processing in Vango Metering Architecture .....	38
Figure 6-2 Analog Input of Current Channels .....	39
Figure 6-3 Analog Input of Voltage Channels .....	40
Figure 6-4 Channel Selection for Current Signal Processing.....	42
Figure 6-5 Phase Compensation .....	43
Figure 6-6 Digital Input and DC Removal (Current Signal is Taken as an Example.) .....	44
Figure 6-7 Total / Fundamental RMS Calculation .....	46
Figure 6-8 Active/Reactive Power Calculation.....	47
Figure 6-9 Energy Accumulation and CF Pulse Output .....	50
Figure 6-10 Signal Processing in M Channel.....	53
Figure 7-1 Structure of an 11-Bit Data Byte.....	61
Figure 7-2 Command Frame for Read/Write/Broadcast Operation.....	61
Figure 7-3 Timing of UART Communication .....	62
Figure 8-1 Zero-Crossing Interrupt.....	68
Figure 8-2 Signal Processing for Current Detection .....	69
Figure 8-3 Current Detection Interrupt.....	69

# Table List

Table 1-1 Reset Related Registers.....	19
Table 2-1 Clock Generation Related Registers .....	22
Table 3-1 States of Functional Units in Default State .....	26
Table 3-2 States of Functional Units in Metering Mode.....	27
Table 3-3 States of Functional Units in Sleep Mode.....	28
Table 3-4 States of Functional Units in Current Detection Mode.....	30
Table 3-5 Factors Affecting Power Dissipation .....	31
Table 3-6 Effects on ADCs Power Dissipation .....	31
Table 3-7 Effect on Vango metering architecture Power Dissipation .....	31
Table 3-8 Power Dissipation of Measurement Channel.....	32
Table 3-9 Power Dissipation in Each Operating Mode .....	32
Table 4-1 DVCCLD0 Output Voltage Adjustment.....	34
Table 5-1 Configuration for Bandgap Circuit.....	36
Table 6-1 Analog PGA Configuration .....	40
Table 6-2 Enable/Disable ADCs of Each Channel .....	41
Table 6-3 Configuring ADCCLK.....	41
Table 6-4 Channel Selection for Current Signal Processing.....	42
Table 6-5 Registers for phase compensation .....	43
Table 6-6 Resolution and correction range at different frequencies.....	43
Table 6-7 Enable/Disable Digital Inputs .....	44
Table 6-8 DPGA Gain Selection for Digital Signals .....	45
Table 6-9 Registers for Energy Accumulation and CF Pulse Output .....	50
Table 6-10 Registers and Bits for No-Load Detection .....	51
Table 6-11 Bandpass Filter Parameters .....	52
Table 6-12 Registers for M Channel Configuration.....	53
Table 6-13 Data Registers for M Channel.....	54
Table 6-14 Registers for Meter Calibration .....	55
Table 7-1 UART Communication Timing Parameters.....	62
Table 7-2 Structure of Data Byte (B7:B0) From Master MCU to V9261F on Write Operation ..	63
Table 7-3 Structure of Data Byte (B7:B0) From V9261F to Master MCU on Write Operation ..	63

<b>Table 7-4 Structure of Data Byte (B7:B0) From Master MCU to V9261F on Read Operation ...</b>	<b>64</b>
<b>Table 7-5 Structure of Data Byte (B7:B0) From V9261F to Master MCU on Read Operation ...</b>	<b>64</b>
<b>Table 7-6 Structure of Data Byte (B7:B0) From Master MCU to V9261F on Broadcast Operation .....</b>	<b>65</b>
<b>Table 8-1 Registers for Configuration Verification .....</b>	<b>67</b>
<b>Table 8-2 Interrupt Flag Bits .....</b>	<b>69</b>
<b>Table 9-1 Analog Control Register 0 (ANCtrl0, 0x0185) .....</b>	<b>72</b>
<b>Table 9-2 Analog Control Register 1 (ANCtrl1, 0x0186) .....</b>	<b>75</b>
<b>Table 9-3 Analog Control Register 2 (ANCtrl2, 0x0187) .....</b>	<b>76</b>
<b>Table 9-4 System Control Register (0x0180, SysCtrl) .....</b>	<b>78</b>
<b>Table 9-5 Metering Control Register 0 (0x0183, MTPARA0) .....</b>	<b>81</b>
<b>Table 9-6 Metering Control Register 1 (0x0184, MTPARA1) .....</b>	<b>83</b>
<b>Table 9-7 Registers for DC Component (R/W) .....</b>	<b>85</b>
<b>Table 9-8 Registers for Line Frequency (R) .....</b>	<b>85</b>
<b>Table 9-9 Registers for RMS Values of Total/Fundamental Signals (R/W) .....</b>	<b>86</b>
<b>Table 9-10 Total/Fundamental Active/Reactive Power Registers (R/W) .....</b>	<b>89</b>
<b>Table 9-11 Active/Reactive Energy Accumulators (R/W) .....</b>	<b>91</b>
<b>Table 9-12 Active/Reactive CF Pulse Counters (R/W) .....</b>	<b>91</b>
<b>Table 9-13 Power Register (R/W) .....</b>	<b>92</b>
<b>Table 9-14 Registers for Presetting Bias for Direct Current/Voltage .....</b>	<b>92</b>
<b>Table 9-15 Registers for Calibrating Voltage/Current RMS (R/W) .....</b>	<b>92</b>
<b>Table 9-16 Registers for Calibrating Active/Reactive Power (R/W) .....</b>	<b>93</b>
<b>Table 9-17 Threshold Register .....</b>	<b>94</b>
<b>Table 9-18 Register for Bandpass Filter Coefficient Configuration (0x0125, BPF PARA, R/W) .....</b>	<b>94</b>
<b>Table 9-19 Checksum Register (0x0133, CKSUM, R/W) .....</b>	<b>94</b>

# 1. Reset

In V9261F, the chip will be reset to the Default State when a POR, RX reset, or global software reset occurs.

## 1.1. Power-On Reset (POR)

In V9261F, the internal power-on reset circuit supervises the output voltage on pin "DVCC" all the time. When the output voltage is lower than 1.45 V, the reset signal will be generated and force the chip into the reset state. When the output voltage is higher than 1.45 V, the reset signal will be released and the chip will get to the Default State in 500  $\mu$ s.

When a POR event occurs, the bit "RSTSRC" (bit[26:24] of SysCtrl, 0x0180) will be reset to "0b001".

In the reset state, the master MCU and the Vango metering architecture cannot access RAM. When the chip exits from the reset state, RAM will implement the self-checking in about 1.25 ms. If there is no error occurring, RAM can be accessed.

In the reset state, the UART serial interface is idle. The UART serial interface starts to run immediately once the chip exits from the reset state.

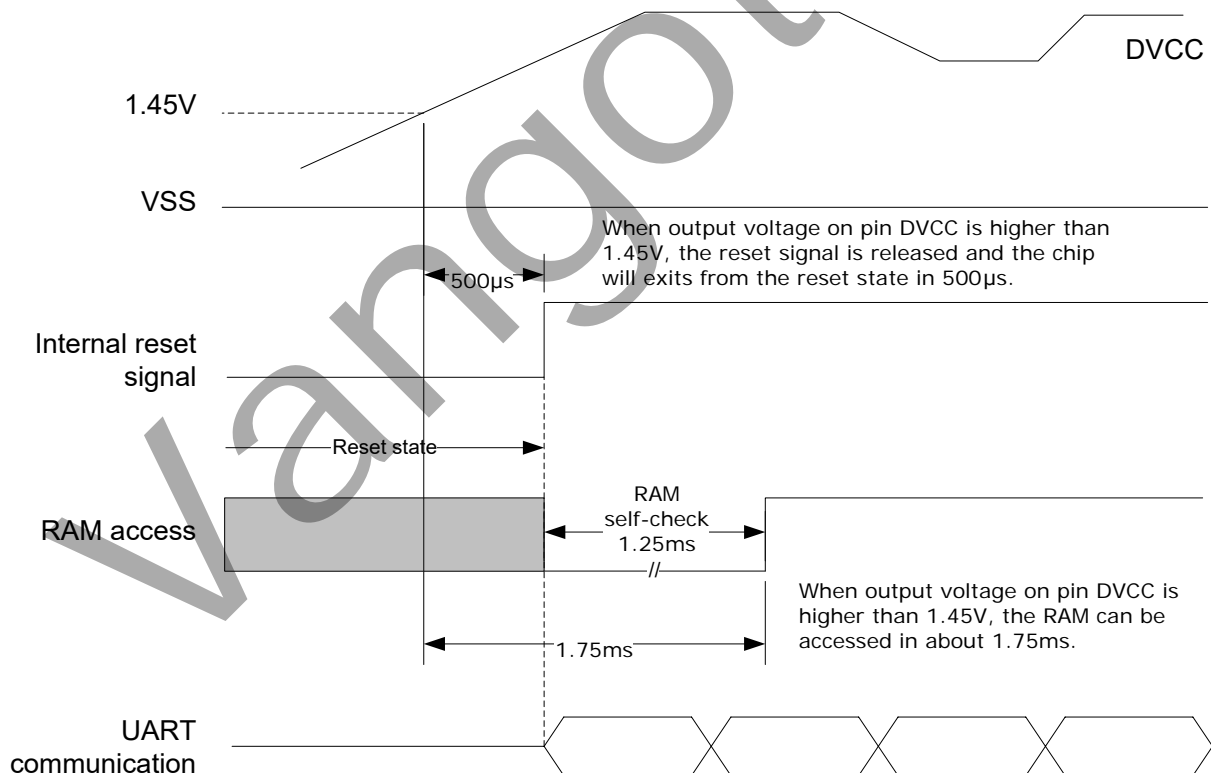

Figure 1-1 Timing of POR

## 1.2. RX Reset

The input on pin "RX" must be driven low for at least 64 ms to force the chip into the reset state. Pull to the logic high, and 900  $\mu$ s later the chip will exit from the reset state and get back to the Default State.

When the "RX" reset occurs, the bit "RSTSRC" (bit[26:24] of SysCtrl, 0x0180) will be reset to "0b011".

In the reset state, the master MCU and the Vango metering architecture cannot access RAM. When the chip exits from the reset state, RAM will implement the self-checking in about 1.25 ms. If there is no error occurring, RAM can be accessed.

In the reset state, the UART serial interface is idle. The UART serial interface starts to run immediately once the chip exits from the reset state.

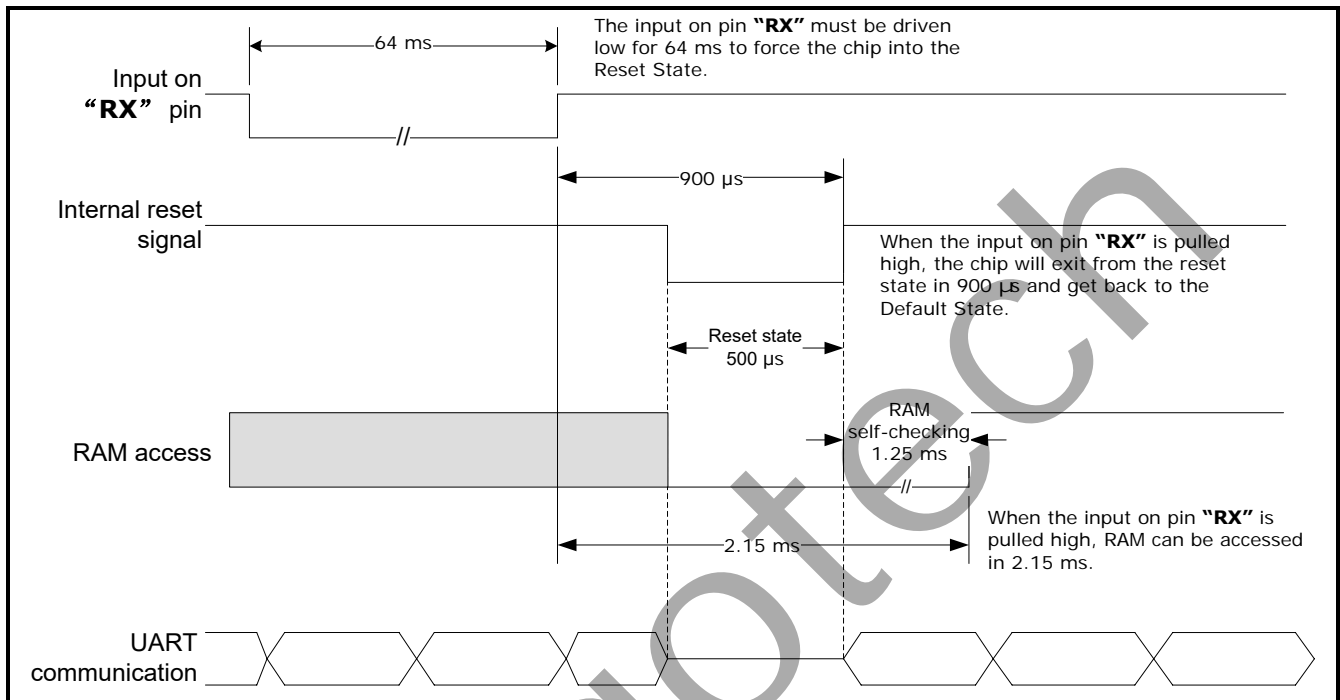

Figure 1-2 Timing of RX Reset

## 1.3. Global Software Reset

In V9261F, writing of "0x4572BEAF" in the register "SFTRST" (0x01BF) can force the chip into the Reset State, and the chip will exit and get back to Default State in 650 μs.

When the global software reset occurs, the bit "RSTSRC"(bit[26:24] of SysCtrl, 0x0180) will be reset to "0b100".

In the Reset State, the master MCU and the Vango metering architecture can not access RAM. When the chip exits from the Reset State, RAM will implement the self-checking in about 1.25 ms. If there is no error occurring, RAM can be accessed.

In the Reset State, the UART serial interface is idle. The UART serial interface starts to run immediately once the chip exits from the Reset State.

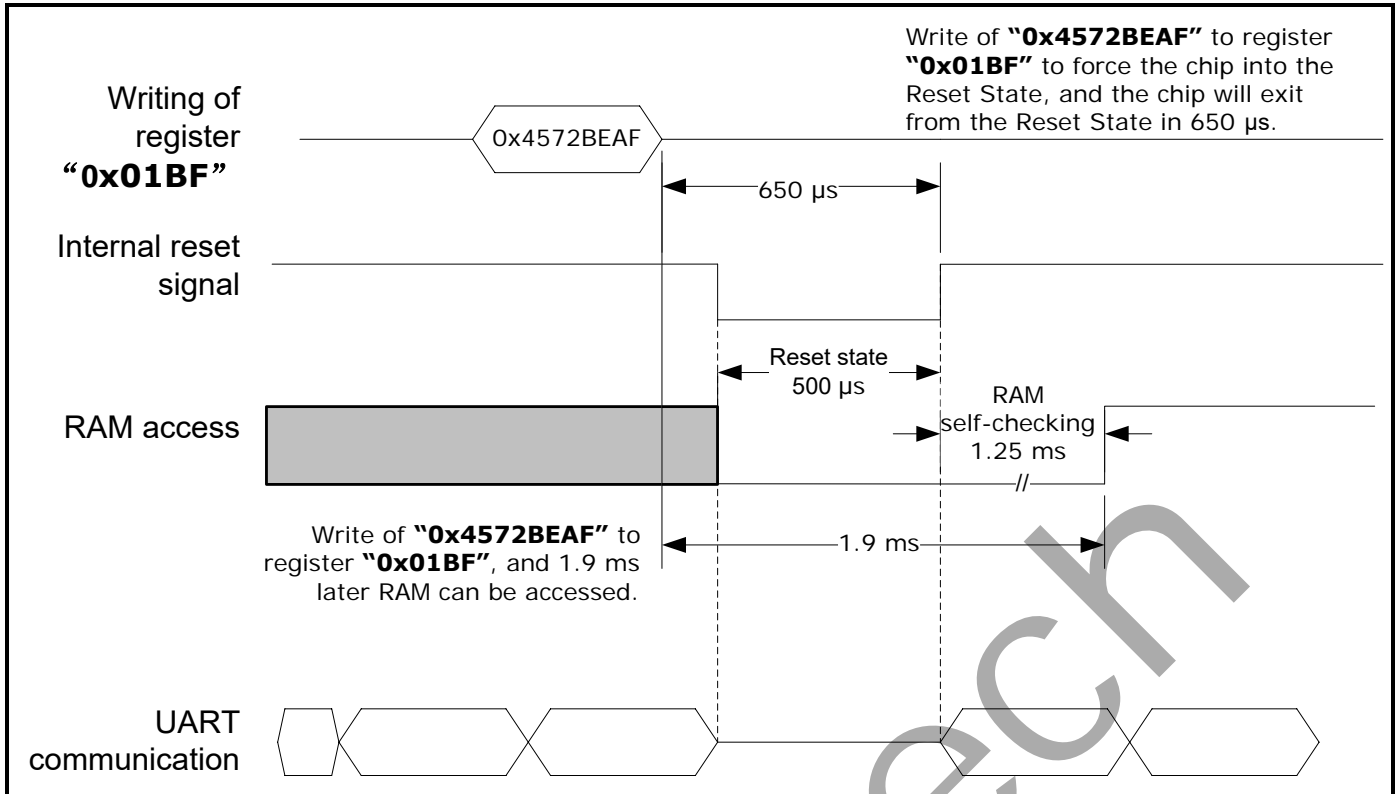

Figure 1-3 Timing of Global Software Reset

## 1.4. Registers

Table 1-1 Reset Related Registers

Register	Bit	Description																								
		Flag bits to indicate the reset source																								
		<table border="1"> <thead> <tr> <th>Bit26</th> <th>Bit25</th> <th>Bit24</th> <th>Description</th> </tr> </thead> <tbody> <tr> <td>0</td> <td>0</td> <td>1</td> <td>A POR event occurred.</td> </tr> <tr> <td>0</td> <td>0</td> <td>0</td> <td>Reserved.</td> </tr> <tr> <td>0</td> <td>1</td> <td>1</td> <td>An RX reset event occurred.</td> </tr> <tr> <td>0</td> <td>1</td> <td>0</td> <td>Reserved.</td> </tr> <tr> <td>1</td> <td>0</td> <td>0</td> <td>A global software reset occurred.</td> </tr> </tbody> </table>	Bit26	Bit25	Bit24	Description	0	0	1	A POR event occurred.	0	0	0	Reserved.	0	1	1	An RX reset event occurred.	0	1	0	Reserved.	1	0	0	A global software reset occurred.
Bit26	Bit25	Bit24	Description																							
0	0	1	A POR event occurred.																							
0	0	0	Reserved.																							
0	1	1	An RX reset event occurred.																							
0	1	0	Reserved.																							
1	0	0	A global software reset occurred.																							
0x0180 SysCtrl	Bit[26:24] RSTSRC																									
0x01BF, SFTRST Software Reset Control Register		Readable and writable, in the form of 32-bit 2' complement. Write "0x4572BEAF" to the register to reset the system.																								

## 2. Clock

The on-chip RC oscillator circuits and the crystal oscillation circuit provide clocks for V9261F:

- On-chip crystal oscillation circuit: An external 6.5536-MHz or 3.2768-MHz crystal connects to the pins **"CTI"** and **"CTO"** to generate the clock, **"CLK1"**, which works as the clock source for the Vango metering architecture, ADCs, and UART serial interface. After a POR, RX reset, or global software reset, this oscillation circuit starts to run.
- On-chip 3.2-MHz (The deviation is within  $\pm 30\%$  from chip to chip for mass production. The temperature deviation from  $-40\sim 85$  degree for each specific chip is less than 3%.) RC oscillator generates the clock, **"CLK2"**, which works as an optional clock source for the Vango metering architecture, ADCs, and UART serial interface. This circuit can be disabled. After a POR, RX reset, or global software reset, this circuit stops running.
- On-chip 32-kHz ( $\pm 50\%$ ) RC oscillator generates the clock, **"CLK3"**, which works as the clock source for the wake-up circuit, internal crystal supervising and stimulating circuit, and the filters for some key IO ports. This circuit keeps on working until the system is powered off.

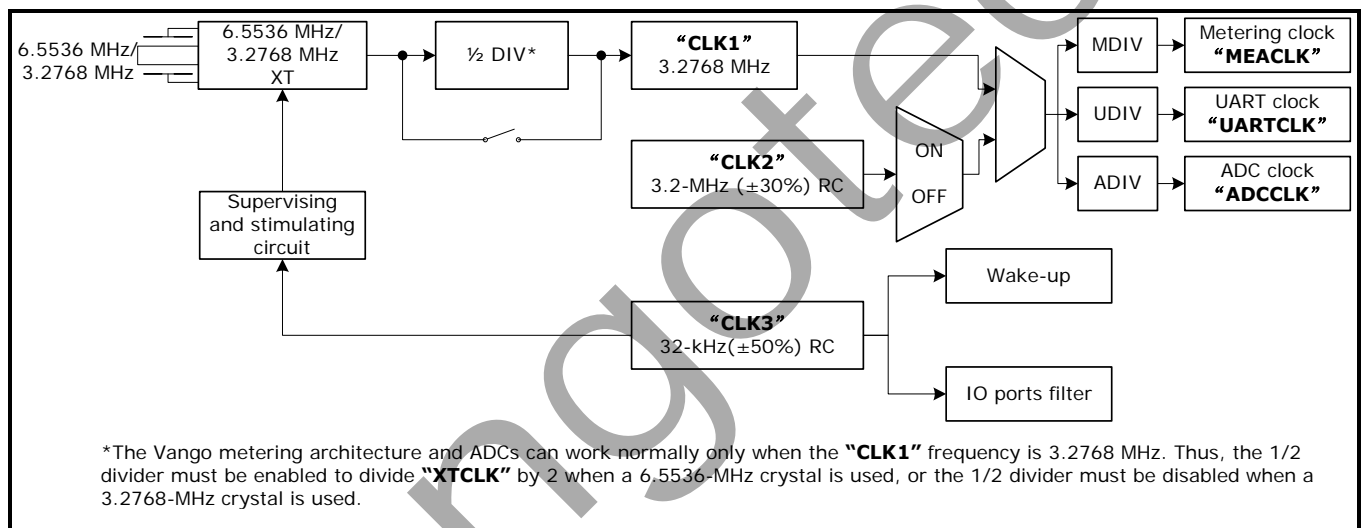

Figure 2-1 Clock Generation

### 2.1. Crystal Oscillation Circuit

In the on-chip crystal oscillation circuit, there is fixed load capacitance (CL) of 12 pF. In applications, users can adjust the capacitance via configuring bits **"XCSEL<1:0>"** (bit[17:16] of ANCtrl2, 0x0187) or connecting additional capacitors around pins **"CTI"** and **"CTO"** to adjust the oscillation frequency.

When being powered on, the crystal oscillation circuit will start to run to generate a clock **"XTCLK"** to be the source of clock **"CLK1"**. The **"CLK1"** frequency is divided by different clock scalars to generate clocks for the Vango metering architecture (**"MEACLK"**), ADCs (**"ADCCLK"**), and UART serial interface (**"UARTCLK"**). The master MCU can configure the bit **"XTALPD"** (bit20 of ANCtrl0, 0x0185) to disable the oscillation circuit. When the oscillation circuit stops working, the on-chip 3.2-MHz ( $\pm 30\%$ ) RC oscillator will start to run automatically to generate clock **"CLK2"** to replace **"CLK1"** to provide clock pulses for the metering architecture, ADCs, and UART serial interface. However, please note that the **"CLK2"** frequency is not accurate enough for the UART communication.

Both 3.2768-MHz and 6.5536-MHz crystals can be connected around the pins **"CTI"** and **"CTO"**. Thus, the **"XTCLK"** frequency can be 3.2768 MHz or 6.5536 MHz. But the Vango metering architecture and ADCs can work normally only when the CLK1 frequency is 3.2768 MHz. So, the 1/2 divider must be enabled when a 6.5536-MHz crystal is used; otherwise, it must be disabled. Users can enable or disable this divider via configuring the bit **"XTAL3P2M"** (bit19 of ANCtrl0, 0x0185).

Please note the 1/2 divider is enabled after a POR, RX reset, or global software reset occurs. So the UART interface will communicate at a half of the expected baud rate when 3.2768-MHz crystal is used. Users must disable the 1/2 divider via the bit **"XTAL3P2M"** (bit19 of ANCtrl0, 0x0185).

Users can adjust the clock frequency for ADCs and metering architecture via bits **"ADCCLKSEL<1:0>"** (bit[17:16] of ANCtrl0, 0x0185) and **"CKMDIV"** (bit1 of SysCtrl, 0x0180).

The typical power dissipation of the crystal oscillation circuit is 130  $\mu$ A. When a 3.2768-MHz crystal is used, users must set bit **"XTALLP"** to '1' to lower the power dissipation to a half. When a 6.5536-MHz crystal is used, setting this bit has no effect on the power dissipation of this circuit. When a crystal of higher than 60- $\Omega$  ESR (Equivalent Serial Resistance) is used, users must set the bit **"XRSEL<0>"** (bit18 of ANCtrl2, 0x0187) to '1' to improve the driving ability of the oscillation circuit to ensure the crystal to work, which needs additional 55- $\mu$ A load current.

In the Metering Mode, some errors can stop the oscillation circuit. So, an internal supervising and stimulating circuit, which is sourced by **"CLK3"**, is designed to monitor the crystal all the time. When the crystal stops oscillating, this circuit will generate a 1-ms wide pulse every second to stimulate the crystal to restore oscillating. The stimulating function of this circuit is disabled by default. Users can set the bit **"XRSTEN"** (bit21 of ANCtrl0, 0x0185) to '1' to enable this function.

In the Sleep Mode, this crystal oscillation circuit stops working, and it will not get back to work automatically even though the system is woken up from the Sleep Mode to get to the Current Detection Mode.

When the crystal stops working, an interrupt signal will be generated and the flag bit **"HSEFAIL"** (bit27 of SysCtrl, 0x0180) is set to '1', which will be cleared when the crystal restores to work.

Please note that the **"CLK2"** frequency is not accurate enough for the UART communication, so the master MCU cannot read the actual state of the flag bit **"HSEFAIL"**.

## 2.2. 3.2-MHz RC Oscillator

In V9261F, an on-chip 3.2-MHz RC oscillator is designed to generate a 3.2768-MHz (The deviation is within  $\pm 30\%$  from chip to chip for mass production. The temperature deviation from -40~85 degree for each specific chip is less than 3%.) clock, **"CLK2"**, to work as an optional clock source for the Vango metering architecture, ADCs, and UART serial interface. But the **"CLK2"** frequency is not accurate enough for the UART communication. In the Metering Mode, this circuit will start to run automatically when the crystal stops working, and it will stop running automatically when the crystal restores to work.

After a POR, RX reset, or global software reset occurs, this circuit stops running. To enable this circuit, it is mandatory to enable the Bandgap and global biasing current circuits firstly which provide the biasing current and reference voltage for the 3.2-MHz RC oscillator.

In the Sleep Mode, this circuit stops running, and it will get back to work automatically when the chip is woken up from the Sleep Mode to get to the Current Detection Mode.

## 2.3. 32-kHz RC Oscillator

The on-chip 32-kHz RC oscillator can generate a 32-kHz ( $\pm 50\%$ ) RC clock, "**CLK3**", to drive the wake-up circuit, internal crystal supervising and stimulating circuit, and the filters for some key IO ports. This oscillator cannot be disabled until the system is powered off.

## 2.4. Registers

**Table 2-1 Clock Generation Related Registers**

Register	Bit	Default	Description
0x0185 ANCtrl0	Bit29 PDRCLK	N/A	<p>Clear this bit to enable the 3.2-MHz RC Clock. It is mandatory to enable the Bandgap circuit and biasing circuit firstly. The value of the bit is uncertain when the system is reset.</p> <p>In the Sleep Mode, this bit is set to <b>'1'</b> automatically. In the Current Detection Mode, this bit is cleared automatically.</p> <p>In the Metering Mode, when the chip operates with full functions, it is recommended to disable this circuit (Set the bit to <b>'1'</b>).</p>
	Bit28 BIASPDN	0	<p>Set this bit to <b>'1'</b> to enable the biasing circuit to provide the global biasing current for ADCs and the 3.2-MHz RC oscillator. Therefore, in the Metering Mode, when the chip operates with full functions, this bit must be set to <b>'1'</b> before enabling ADCs and the 3.2-MHz RC oscillator. By default the biasing circuit is disabled.</p> <p>In the Sleep Mode, this bit is cleared automatically. In the Current Detection Mode, this bit is set to <b>'1'</b> automatically.</p>
	Bit27 BGPPDN	0	<p>Set this bit to <b>'1'</b> to enable the Bandgap circuit to provide ADCs and the 3.2-MHz RC oscillator with the reference voltage and biasing voltage. Therefore, in the Metering Mode, when the chip operates with full functions, this bit must be set to <b>'1'</b> before enabling ADCs and the 3.2-MHz RC oscillator. By default the Bandgap circuit is disabled.</p> <p>In the Sleep Mode, this bit is cleared automatically. In the Current Detection Mode, this bit is set to <b>'1'</b> automatically.</p>
	Bit21 XRSTEN	0	<p>Set this bit to <b>'1'</b> to enable the function of stimulating the external crystal when it stops running. By default this function is disabled.</p> <p>In the Metering Mode, when the chip operates with full functions, it is recommended to enable this function for the best performance.</p>

Register	Bit	Default	Description
	Bit20 XTALPD	0	<p>Set this bit to '1' to disable the crystal oscillation circuit. By default this circuit is enabled. In the Metering Mode, when the chip operates with full functions, this bit will be set to '1' when the external crystal stops running, but it will be cleared automatically when the crystal restores running.</p> <p>Both in the Sleep Mode and the Current Detection Mode, this bit is set to '1' automatically.</p>
	Bit19 XTAL3P2M	0	<p>When a 3.2768-MHz external crystal is used, this bit must be set to '1' to disable the 1/2 divider in the crystal oscillation circuit.</p> <p>When a 6.5536-MHz crystal is used, this bit must be cleared to enable the 1/2 divider.</p>
	Bit18 XTALLP	0	<p>When a 3.2768-MHz crystal is used, it is mandatory to set this bit to '1' to lower the power dissipation of the crystal oscillation circuit to a half.</p> <p>When a 6.5536-MHz crystal is used, this bit must hold its default value.</p>
	Bit[17:16] ADCLKSEL<1:0>	0	<p>To select the sampling frequency of the oversampling ADC (ADC clock, "ADCCLK")</p> <p>The sampling frequency of ADCs must be a quarter or one eighth of the metering clock ("MEACLK") frequency when the chip operates with full functions in the Metering Mode.</p> <p>00: 819.2 kHz 01: 409.6 kHz 10: 204.8 kHz 11: 102.4 kHz</p> <p>In the Current Detection Mode, these bits must be set to "0b10" to lower the power dissipation.</p> <p>When the chip operates with full functions in the Metering Mode, their default values are recommended to be used for the best performance.</p>
0x0187 ANCtrl2	Bit[29:24] RCTRIM<5:0>	0	<p>To adjust the 3.2-MHz RC clock cycle</p> <p>The resolution is 1% per LSB. When these bits are in their default state, no adjustment is applied.</p> <p>From "0b000000" to "0b100000", the RC clock cycle is decreased by 1% per LSB; from "0b100001" to "0b111111", the RC clock cycle is increased by 1% per LSB.</p> <p>When the chip operates with full functions in the Metering Mode,</p>

Register	Bit	Default	Description
			it is recommended to hold their default values for the best performance.
	Bit19 XRSEL<1>	0	To adjust the negative resistance of the crystal oscillator It is not recommended to set this bit to '1', which will lead to additional 18-μA load current.
	Bit18 XRSEL<0>	0	To adjust the negative resistance of the crystal oscillator When the equivalent series resistance of the crystal is higher than 60 Ω, it is recommended to set this bit to '1', which will lead to additional 55-μA load current.
	Bit[17:16] XCSEL<1:0>	0	To adjust the load capacitance of the crystal oscillator By default the load capacitance is 12 pF. 00: No adjustment 01: +2 pF 10: +4 pF 11: +6 pF
0x0183 MTPARA0	Bit28 CLKSEL	0	When the "MEACLK" frequency is 3.2768 MHz, clear this bit to inform the CF pulse generation circuit to work at 3.2768 MHz. When the "MEACLK" frequency is 819.2 kHz, set this bit to '1' to inform the CF pulse generation circuit to work at 819.2 kHz.
	Bit4 IEHSE	0	To enable external crystal failure interrupt output 1: Enable 0: Mask
0x0180 SysCtrl	Bit27 HSEFAIL	0	External crystal failure interrupt flag bit When the external crystal stops running, this bit will be set and hold the state till the crystal starts to oscillate again. When the crystal stops running, the UART serial interface is sourced by the 3.2-MHz RC clock ("CLK2") that is not accurate enough for the UART communication, so the master MCU cannot read the value of this bit to detect the state of the crystal.
	Bit1 CKMDIV	0	To select the clock frequency for the Vango metering architecture ("MEACLK") 1: 819.2 kHz 0: 3.2768 MHz
	Bit0 SLEEP	0	Set this bit to '1' to disable "CLK1" and "CLK2" and force the system to enter the Sleep Mode.

Vangotech

### 3. Operation Modes

When V9261F is powered off, the chip will stop working and it will get to the Default State when being powered on.

When the chip is working, it can be reset to the Default State when a POR, RX reset, or global software reset occurs. Table 3-1 lists the states of functional units in V9261F in the Default State.

In the Default State, the typical load current is 500  $\mu$ A. Some easy configurations can drive the chip to work in the Metering Mode or Sleep Mode.

**Table 3-1 States of Functional Units in Default State**

Functional Unit	State
RAM	Cleared to all zeros
Crystal oscillation circuit	Enabled
3.2-MHz RC oscillator	Disabled
32k-Hz RC oscillator	Enabled
Bandgap circuit	Disabled
Biasing circuit	Disabled
Power supply monitoring circuit	Enabled
POR circuit	Enabled
LDO	Enabled
ADC	Disabled
Temperature measurement circuit	Disabled
Vango metering architecture	Enabled, but for configuration verification only.
Interrupt management circuits	Enabled Output the system control register self-checking interrupt and configuration verification interrupt only.
UART serial interface	Enabled When a 3.2768-MHz crystal is used, the actual baud rate is a half of desired baud rate.

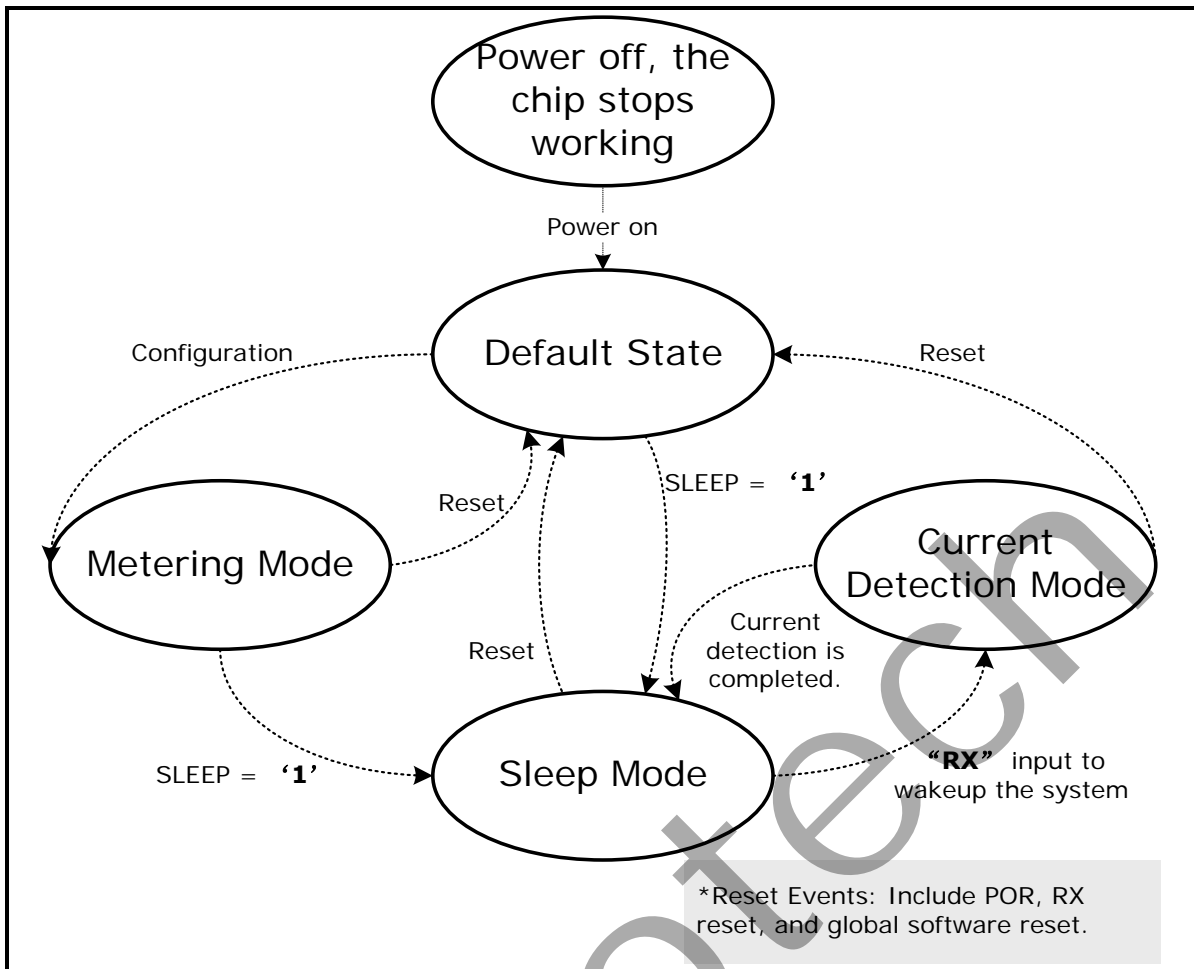

Figure 3-1 Operating Modes

### 3.1. Metering Mode

In the Default State, V9261F will enter the Metering Mode via some easy configurations:

- To select **"CLK1"** to source the clocks of the Vango metering architecture (**"MEACLK"**), UART serial interface (**"UARTCLK"**), and ADCs (**"ADCCLK"**)
- To enable or disable ADCs, to configure the sampling frequency to 819.2 kHz or 204.8 kHz, and to adjust the global biasing current to lower the power dissipation of ADCs
- To configure the **"MEACLK"** frequency to 3.2768 MHz or 819.2 kHz that must be four or eight times of the **"ADCCLK"** frequency, and to configure the function of the Vango metering architecture

In the Metering Mode, when a reset event, such as a POR, RX reset, or global software reset, occurs, the chip will get back to the Default State.

Table 3-2 States of Functional Units in Metering Mode

Functional Unit	State
Crystal oscillation circuit	Enabled by default. It is mandatory to set bit <b>"XRSTEN"</b> to <b>'1'</b> to enable the function of stimulating the external crystal when it stops running.

Functional Unit	State
3.2-MHz RC oscillator	It is recommended to disable this unit to lower the power dissipation. When the crystal oscillation circuit stops running, this unit will start to run automatically.
32-kHz RC oscillator	Enabled
Bandgap circuit	It is mandatory to enable this unit.
Biasing circuit	It is mandatory to enable this unit.
Power supply monitoring circuit	Enabled
POR circuit	Enabled
LDO	Enabled Configure the DVCCLDO to lower power dissipation of the Vango metering architecture.
ADC	Enable ADCs, configure the sampling frequency, and adjust the global biasing current to lower the power dissipation, to meet the application requirements.
Temperature measurement circuit	Enable or disable to meet the application requirements.
Vango metering architecture	It is mandatory to enable this unit, and configure its functions to meet the application requirements.
Interrupt management circuits	Enabled Output system control register self-checking interrupt and configuration verification interrupt all the time, and output the desired interrupts to meet the application requirements.
UART serial interface	Enabled

## 3.2. Sleep Mode

When V9261F is in the Default State or Metering Mode, set the bit **"SLEEP"** (bit0, SysCtrl, 0x0180) to '1' to enable the system to enter the Sleep Mode.

**Table 3-3 States of Functional Units in Sleep Mode**

Functional Units	State
Crystal oscillation circuit	Enabled
3.2-MHz RC oscillator	Disabled
32-kHz RC oscillator	Enabled

Functional Units	State
Bandgap circuit	Disabled automatically
Biasing circuit	Disabled automatically
Power supply monitoring circuit	Enabled
POR circuit	Enabled
LDO	Enabled
ADC	Disabled automatically
Temperature measurement circuit	Disabled automatically
Vango metering architecture	Disabled automatically
Interrupt management circuits	Enabled It is recommended to mask all interrupt output before Sleep Mode, except system control register self-check interrupt, which outputs all the time.
UART serial interface	IDLE

In the Sleep Mode, the clock generation circuits, except for the 32-kHz RC oscillator, stop working, so the Vango metering architecture and ADCs stop working, the UART interface is idle, but the interrupt management circuits keep working. In this mode, the pin "CF" outputs the low logic, and the pin "TX" outputs the high logic. It is recommended to disable the interrupt output before entering the Sleep Mode except for the system control register self-checking interrupt.

The typical load current in the Sleep Mode is 10  $\mu$ A.

In the Sleep Mode, a low-to-high transition (Holding low for 250  $\mu$ s and then high for 250  $\mu$ s) on the pin "RX" can wake up the system to work in the Current Detection Mode; when a reset event, such as a POR, RX reset, or global software reset, occurs, the system will get to the Default State.

### 3.3. Current Detection Mode

In the Sleep Mode, a low-to-high transition (Holding low for  $\geq 250 \mu$ s) on the pin "RX" can wake up the system to work in the Current Detection Mode.

In the Current Detection Mode,

- The 3.2-MHz RC oscillator generates "CLK2" to source "MEACLK", "ADCCLK", and "UARTCLK". The RC oscillator will oscillate in 1 ms.
- The "MEACLK" frequency is fixed at 3.2768 MHz to ensure that the current signal is sampled 256 times every cycle.
- Only the current channel ADC is enabled. To lower the power dissipation and speed up the detection, it is recommended to lower the sampling frequency to 204.8 kHz, lower the global biasing current by 66%, and decrease the DVCCLD0 output voltage by 0.2 V. All these configurations can lower the power dissipation to 0.85 mA.

It takes no more than 13 ms to complete the current detection. When the detection is completed, the system will get back to the Sleep Mode automatically.

In the Current Detection Mode, all interrupt outputs, except for those of system control register self-checking interrupt, configuration verification interrupt, and current detection interrupt, are masked.

**Table 3-4 States of Functional Units in Current Detection Mode**

Functional Units	State
Crystal oscillation circuit	Disabled
3.2-MHz RC oscillator	Enabled automatically
32-kHz RC oscillator	Enabled
Bandgap circuit	Enabled automatically
Biassing circuit	Enabled automatically It is recommended to lower the global biassing current by 66% to lower the power dissipation.
Power supply monitoring circuit	Enabled
POR circuit	Enabled
LDO	Enabled It is recommended to lower the DVCC LDO by 0.2 V to lower the power dissipation of the Vango metering architecture.
ADC	Only current channel ADC is enabled. It is mandatory to lower the "ADCCLK" frequency to 204.8 kHz to accelerate the current detection when the global biassing current is lowered by 66%.
Temperature measurement circuit	Disabled automatically
Vango metering architecture	Enabled and configured to compute for configuration verification and current detection only automatically.
Interrupt management circuits	Enabled All interrupt outputs, except for those of system control register self-checking interrupt, current detection interrupt, and configuration verification interrupt, are masked.
UART serial interface	The "UARTCLK" frequency is not accurate enough for the UART communication.

## 3.4. Power Dissipation

The global power dissipation of V9261F is affected by the DVCC LDO output voltage, ADC sampling frequency ("ADCCLK"), metering clock frequency ("MEACLK") and the global biassing current.

**Table 3-5 Factors Affecting Power Dissipation**

Functional Unit	Affected by				Load current (μA)
	DVCCLD0 output voltage	ADCCLK	MEACLK	Global biasing current	
Bandgap circuit	x	x	x	x	79
Biasing circuit	x	x	x	x	69
Voltage channel ADC	x	•	x	•	-
Current channel ADC	x	•	x	•	-
Vango metering architecture	•	x	•	x	-
Crystal oscillation circuit	x	x	x	x	130*
3.2-MHz RC oscillator	x	x	x	x	40

X: No effects on the power dissipation

•: Affect the power dissipation

\*When a crystal of higher than 60-Ω ESR is used, it is recommended to set the bit "XRSEL<0>" (bit18 of ANCtrlr2, 0x0187) to '1' to improve the driving capability of the oscillation circuit. This configuration will lead to additional 55-μA load current. When a 3.2768-MHz crystal is used, it is mandatory to set the bit "XTALLP" (bit18 of ANCtrlr0, 0x0185) to '1' to lower its power dissipation to a half.

**Table 3-6 Effects on ADCs Power Dissipation**

Functional Unit	ADCCLK	Global Biasing Current Adjustment	Load Current (μA)
Voltage channel ADC	819.2 kHz	0	289
		-33%	215
	204.8 kHz	-66%	113
Current channel ADC	819.2 kHz	0	420
		-33%	309
	204.8 kHz	-66%	155

**Table 3-7 Effect on Vango metering architecture Power Dissipation**

Functional Unit	MEACLK	DVCCLD0 Output Voltage Adjustment	Load Current (μA)
Vango metering architecture	3.2768 MHz	0	720
		+0.2V	782

The "MEACLK" frequency can affect the power dissipation of the Vango metering architecture. But lower the "MEACLK" frequency weakens the metering accuracy, and slows down the voltage and current RMS update. So in the Metering Mode, users should not adjust the "MEACLK" frequency to lower the power

dissipation.

The configuration of bits **"MEAS"** (bit[7:5] of SysCtrl, 0x0180) has effects on the power dissipation of the various signal measurement channel.

**Table 3-8 Power Dissipation of Measurement Channel**

Test Condition	Configuration of "MEAS" Bit[7:5] of SysCtrl, 0x0180	Load Current (µA)
DVCCLDO output voltage adjustment: +0 V "ADCCLK" frequency: 819.2 kHz "MEACLK" frequency: 3.2768 MHz Global biasing current adjustment: -33%	000: Current input on pins "IBP"/"IBN"	523
	100: Temperature	699
	101: Ground	819
	110: Ground	819
	111: Ground	889

The following table lists the typical power dissipation in each operating mode.

**Table 3-9 Power Dissipation in Each Operating Mode**

Operating Mode		Metering Mode (Only voltage and current channels are enabled)		Current Detection Mode	Sleep Mode
		Configuration 1	Configuration 2		
Test Condition	DVCCLDO Output Voltage Adjustment	0	0	-0.2 V	0
	ADCCLK Frequency	819.2 kHz	819.2 kHz	204.8 kHz	-
	MEACLK Frequency	3.2768 MHz	3.2768 MHz	3.2768 MHz	-
	Global Biasing Current Adjustment	-33%	-33%	-66%	0
	Crystal Oscillation Circuit	6.5536 MHz	3.2768 MHz	Disabled	Disabled
	3.2-MHz RC Oscillator	Disabled	Disabled	Enabled	Disabled
Typical Load Current		1.61 mA	1.55 mA	0.85 mA	10 µA

## 4. Power Supply

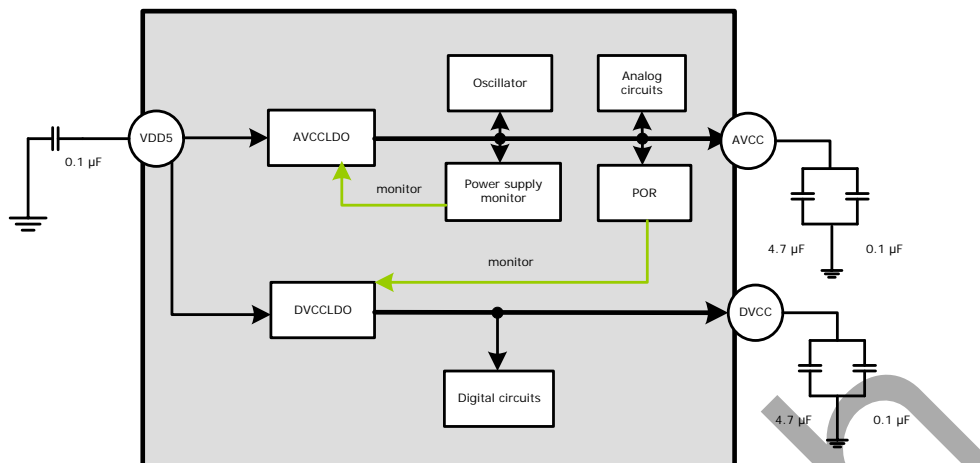

**Figure 4-1 Power Supply Architecture**

The V9261F supports single power input 5V (3.0~5.5V). The analog circuits, such as ADCs, Bandgap circuits, and the oscillators, are powered by the output of AVCCCLDO. And the digital circuits are powered by the output of DVCCCLDO, the digital power supply circuit.

When the input voltage is higher than 3.3V, the internal LDO circuit (AVCCCLDO) will keep the power of AVCC 3.3V output to prevent the performance variation in analog circuit caused by the ripple from the VDD5 source. When VDD5 is lower than 3.3V, V9261F will disable the AVCCCLDO automatically, and then the power of AVCC will be switched to VDD5 power.

The driving capability of AVCC is 30mA. It means AVCC could keep stable output voltage when the power consumption is less than 30mA. Otherwise, the output voltage of AVCC will drop when the load current in analog circuit increased. AVCC should be connected to one parallel circuit combined with a  $\geq 4.7\mu\text{F}$  capacitor and a  $0.1\mu\text{F}$  decoupling capacitor.

### 4.1. Power Supply Monitoring Circuit

In the V9261F, an internal power supply monitoring circuit is designed to supervise the power AVCC. When the AVCC is lower than 2.8V ( $\pm 5\%$ ), a power-down interrupt signal is triggered, and the flag bit PDN (bit28 of SysCtrl, 0x0180) is set to 1, that will be cleared automatically when the power down event disappears.

When the voltage on pin AVCC is less than 2.8V, "PDN\_R" (bit22,0x0180) is set to '1', that will be fix as "1", when the power supply is higher than 2.8 V ( $\pm 5\%$ ), until user clear it by writing any data to SysCtrl register (0x0180).

When the voltage on pin AVCC is lower than 2.8V, if "CF PROT" (Bit7,0x0183) is set to '1', the output of CF will be fixed as '0'. And the energy counter/CF counter will remain operating to realize the under voltage protection of CF output.

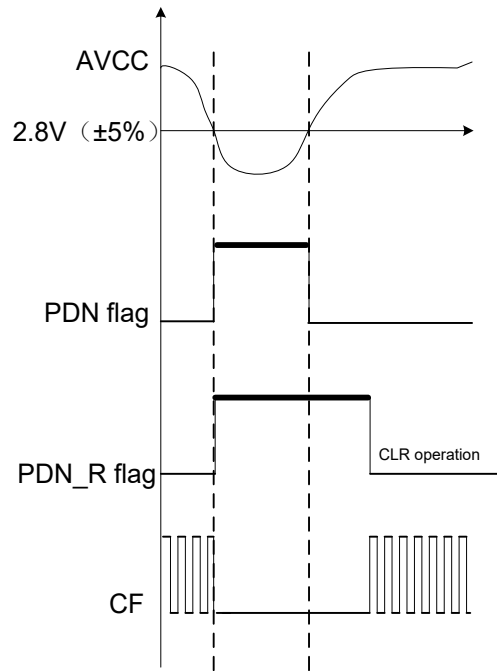

Figure 4-2 Power-Down Interrupt

## 4.2. Digital Power Supply

The digital power supply (DVCCLDO) for digital circuits is derived by an on-chip LDO powered by AVCCCLDO. This DVCCLDO keeps working even though the system is powered down.

This DVCCLDO has a driving capability of 35 mA, which means when the load current on the digital circuits is less than 35 mA, this DVCCLDO will output a stable voltage; but when the load current is higher than 35 mA, the output will reduce as the current increases.

It is recommended to decouple the pin "DVCC" externally with a  $\geq 4.7\text{-}\mu\text{F}$  capacitor in parallel with a  $0.1\text{-}\mu\text{F}$  capacitor.

## 4.3. Registers

Table 4-1 DVCCLDO Output Voltage Adjustment

Register	Bit	Default	Description
ANCtrl2 0x0187	Bit[14:12] LDOVSEL<2:0>	0	To adjust the DVCCLDO output voltage 000: No adjustment 001: -0.1 V 010: +0.2 V 011: +0.1 V 100: -0.4 V 101: -0.5 V

			110: -0.2 V 111: -0.3 V
--	--	--	----------------------------

Vangotech

## 5. Bandgap Circuit

In V9261F, the Bandgap circuit outputs a reference voltage and bias voltage, about 1.188 V with a typical temperature coefficient of 10 ppm/°C, for ADCs and the 3.2-MHz RC oscillator. The Bandgap circuit must be enabled before ADCs and the RC oscillator, and typically, this circuit consumes about 0.08 mA.

By default the Bandgap circuit is disabled. Users can set the bit **"BGPPDN"** (bit27 of ANCtrl0, 0x0185) to **'1'** to enable the Bandgap circuit. In the Sleep Mode, this circuit is disabled automatically; and in the Current Detection Mode, this circuit is enabled automatically.

Users can configure **"bit[14:12]"** and **"bit[9:8]"** of **"ANCtrl0"** register (0x0185) to adjust the temperature coefficient to reduce the temperature coefficient drift introduced by the external components, with the following steps:

1) Assume the current settings of relative bits are REST<2:0>='010' and RESTL<1:0>='00', which means an additional +20ppm for temperature coefficient of Bandgap.

2) Measure meter errors in high and low temperature conditions. Assume user has calibrated the meter error to 0 at 20°C, and the measuring errors are 0.6% at 80°C and -0.4% at -40°C separately. Then a  $-(0.6\% - (-0.4\%))/2 = -0.5\%$  measuring error needs to be compensated relative to high temperature working condition, equivalent to  $-0.5\% / (80 - 20) = -5000/60 = -83\text{ppm}$ , rounding to -80ppm.

3) As measuring error is minus two times of REF temperature coefficient error, to compensate a -80ppm error, an additional +40ppm of Bandgap REF temperature coefficient adjustment is needed. Taking the initial +20ppm setting into consideration, the actual adjustment should be +60ppm. According to the lookup table of RESTL<1:0> and REST<2:0>, user should set register RESTL<1:0> to '01' and REST<2:0> to '111', whose combination equals to a +60ppm temperature coefficient adjustment.

A temperature coefficient drift of **"x"** in the Bandgap circuit results in a drift of **"-2x"** in the measurement error.

**Table 5-1 Configuration for Bandgap Circuit**

Register	bit	Description
ANCtrl0, 0x0185, R/W	Bit27 BGPPDN	Set this bit to <b>'1'</b> to enable the Bandgap circuit to provide ADCs and the 3.2-MHz RC oscillator with the reference voltage and biasing voltage. Therefore, in the Metering Mode, this bit must be set to <b>'1'</b> before enabling ADCs and the 3.2-MHz RC oscillator. By default the Bandgap circuit is disabled.  In the Sleep Mode, this bit is cleared automatically. In the Current Detection Mode, this bit is set to <b>'1'</b> automatically.
	Bit[14:12] REST<2:0>	To finely adjust the temperature coefficient of the Bandgap circuit. In order to obtain the best metering performance and temperature performance during normal metering, it must be configured according to the calculated result. The calculation method, please refer to Bandgap Circuit chapter.  000: No adjustment  001: +10 ppm

Register	bit	Description
		010: +20 ppm 011: +30 ppm 100: -40 ppm 101: -30 ppm 110: -20 ppm 111: -10 ppm
	Bit[9:8] RESTL<1:0>	To roughly adjust the temperature coefficient of the Bandgap circuit. In order to obtain the best metering performance and temperature performance during normal metering, it must be configured according to the calculated result. The calculation method, please refer to Bandgap Circuit chapter. 00: 0 01: +70 ppm 10: -140 ppm 11: -70 ppm

## 6. Energy Metering

The Vango metering architecture in V9261F has features:

- 3 independent oversampling  $\Sigma/\Delta$  ADCs: One for voltage (U), one for current (I) and one for various signal measurement (M)
- High metering accuracy:
  - Less than 0.1% of active energy metering accuracy over dynamic range of 10000: 1
  - Less than 0.1% of reactive energy metering accuracy over dynamic range of 5000: 1
- Various measurements:
  - DC components of voltage/current signals
  - Total/Fundamental raw/instantaneous/average voltage/current RMS
  - Total/Fundamental raw/instantaneous/average active/reactive power
  - Positive/Negative energy, active/reactive selectable
  - Line frequency and temperature
- CF pulse output
- Current detection
- Supporting calibrating meters via software
- Accelerating meter calibration when low current is applied

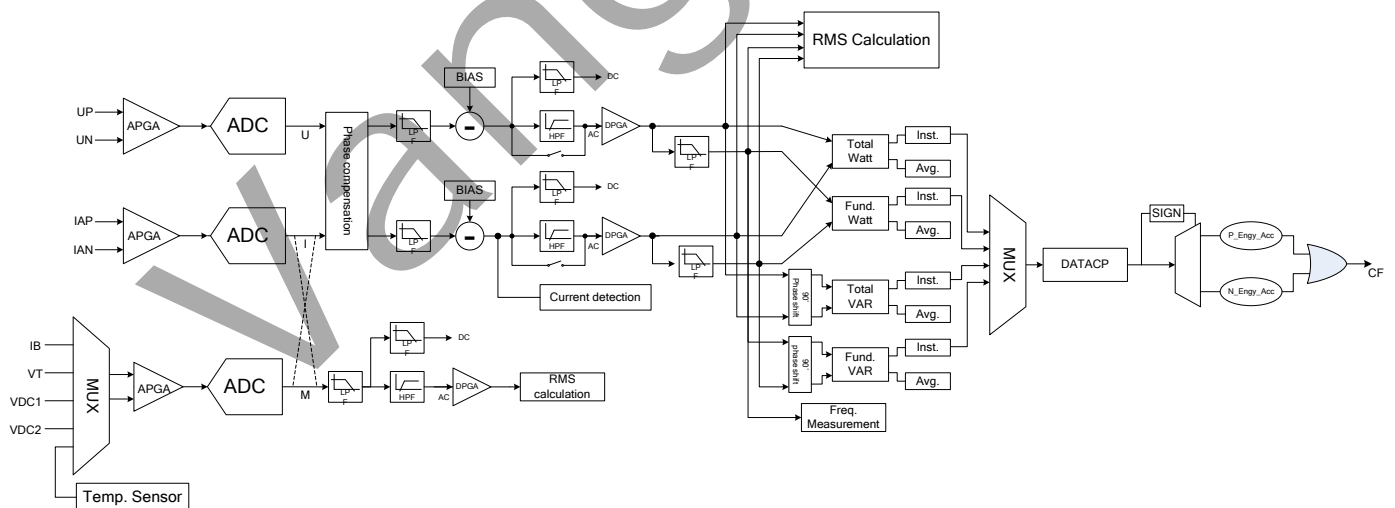

Figure 6-1 Signal Processing in Vango Metering Architecture

### 6.1. Metering Clock ("MEACLK")

The metering clock ("MEACLK") is sourced by "CLK1", generated by crystal oscillation circuit, or "CLK2", generated by the 3.2-MHz RC oscillator. When both circuits stop running, the Vango metering

architecture will stop working.

## 6.2. Analog Input

V9261F has two specific and one optional (M Channel) analog inputs forming two current and one voltage channels. Each current channel consists of two fully-differential voltage inputs. And the voltage channel consists of two pseudo-differential voltage inputs: "UP" is the positive input for the voltage channel, and "UN", connected to the ground, is the negative input for the voltage channel. Each input has a maximum voltage of  $\pm 200$  mV, and each pair of a maximum differential voltage of  $\pm 400$  mV.

For the current channels, a current transformer (CT) or shunt resistor can be used for analog inputs.

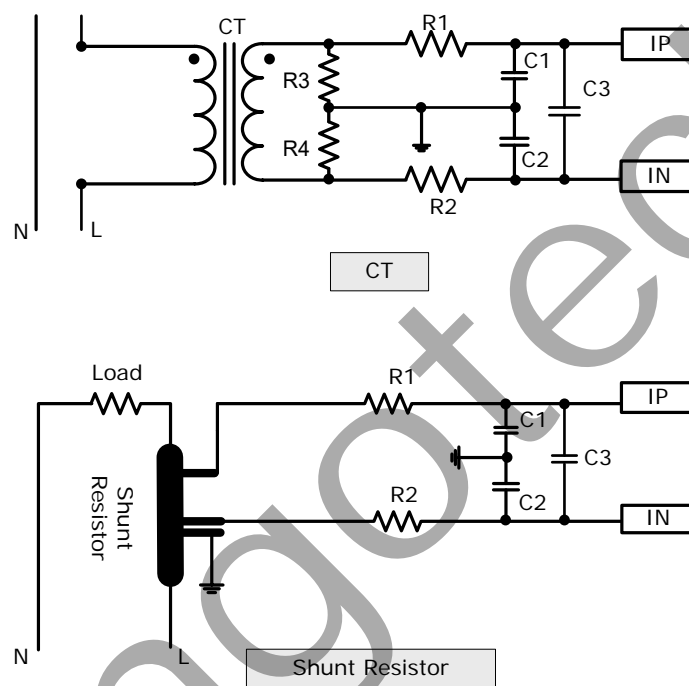

**Figure 6-2 Analog Input of Current Channels**

For voltage channels, a potential transformer (PT) or a resistor-divider network can be used for analog inputs.

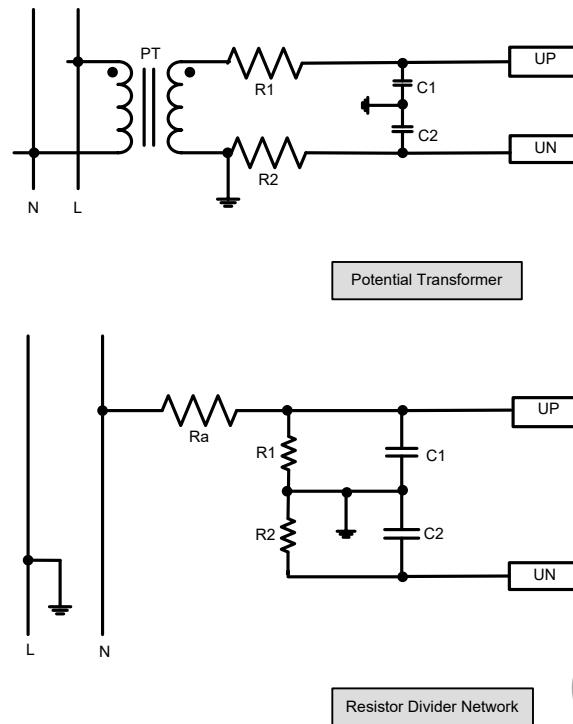

Figure 6-3 Analog Input of Voltage Channels

To match the output signal of the transformers to the measurement scale of ADCs, Analog Programmable Gain Amplifiers (APGA) with possible gain selection of 1, 4, 16, and 32 for current input, and of 1 and 4 for voltage input, are set. The analog PGA gain is determined by the output signal of the transformer. The product of the output signal and PGA gain (Including digital and analog PGA) must be no higher than the voltage reference. Equation 6-1 depicts the signal processing of current and voltage:

$$\begin{aligned}
 U' &= PG Au \times (Au \times \sin \omega t + DC u) \\
 I' &= PG Ai \times [Ai \times \sin (\omega t + \psi) + DC i]
 \end{aligned}
 \tag{Equation 6-1}$$

where  $PGA_u$  and  $PGA_i$  is the analog PGA gain for voltage and current;  $A_u$  and  $A_i$  are the amplitude of the input signals (V);  $DC_u$  and  $DC_i$  are the DC components of the raw voltage and current.

Table 6-1 Analog PGA Configuration

Register	Bit	Default	Description
ANCtrl0 0x0185	Bit7 GU	0	To set analog PGA gain of analog input of Voltage Channel 0: ×4 (Recommended) 1: ×1
	Bit[1:0] GI<1:0>	0	To set analog PGA gain of analog input of Current Channel The analog PGA gain is determined by the output signal of the sensor. The product of the output signal and PGA gain (Both analog and digital) must be no more than the voltage reference. 00: ×32 01: ×16 10: ×4

Register	Bit	Default	Description
			11: ×1
	bit[5:4] GM<1:0>	0	M-channel ADC analog gain control  Users should confirm PGA according to the output signal of sensor and make sure the product of the biggest signal and PGA is smaller than the Bandgap voltage.  00: ×4 01: ×1 10: ×32 11: ×16

### 6.3. Analog-to-Digital Conversion

Second-order  $\Sigma$ - $\Delta$ ADCs are applied in the voltage and current channels in V9261F.  $\Sigma$ - $\Delta$ ADCs can be enabled or disabled via configuring the "ANCtrl0" register (0x0185).

**Table 6-2 Enable/Disable ADCs of Each Channel**

Register	Bit	Default	Description
ANCtrl0 0x0185	Bit26 ADCUPDN	0	Set this bit to '1' to enable Voltage Channel ADC. The Bandgap circuit must be enabled before this ADC.  Both in the Sleep Mode and in Current Detection Mode, this bit is cleared automatically.
	Bit24 ADCIPDN	0	Set this bit to '1' to enable Current Channel ADC. The Bandgap circuit must be enabled before this ADC.  In the Sleep Mode, this bit is cleared automatically. In the Current Detection Mode, this bit is set to '1' automatically.
	bit25 ADCMPPDN	0	To set this bit to '1' to enable M channel ADC  Before enabling ADC, the Bandgap circuit must be enabled first. By default M channel ADC is disabled.  No matter in the Sleep Mode or Current Detection mode, M channel ADC is disabled automatically.

The sampling frequency of ADCs, or ADC clock ("ADCCLK"), is derived from "CLK1". By default, it is 819.2 kHz, a quarter of the metering clock ("MEACLK"), and can be adjusted via "bit[17:16]" of "ANCtrl0" (0x0185).

**Table 6-3 Configuring ADCCLK**

Register	Bit	Description
----------	-----	-------------

Register	Bit	Description
ANCtrl0 0x0185	Bit[17:16] ADCLKSEL<1:0>	<p>To select the sampling frequency of the oversampling ADC (ADC clock, "<b>ADCCLK</b>"). The sampling frequency of ADCs must be a quarter or one eighth of the metering clock ("<b>MEACLK</b>") frequency when the chip operates with full functions in the Metering Mode.</p> <p>00: 819.2 kHz 01: 409.6 kHz 10: 204.8 kHz 11: 102.4 kHz</p> <p>In the Current Detection Mode, these bits must be set to "<b>0b10</b>" to lower the power dissipation.</p> <p>When the chip operates with full functions in the Metering Mode, their default values are recommended to be used for the best performance.</p>

When M Channel ADC is configured to process the current signal input on the pins "**IBP**" and "**IBN**", the two current signals from ADCs can be transferred to Channel I or Channel M separately for the digital signal processing.

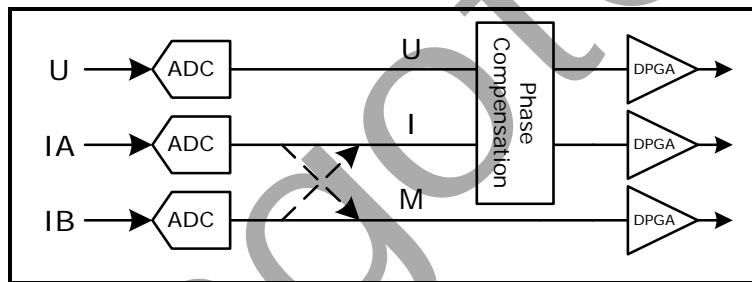

Figure 6-4 Channel Selection for Current Signal Processing

Table 6-4 Channel Selection for Current Signal Processing

Register	Bit	Default	Description
0x0184 MTPARA1	Bit26 SELI	0	<p>To select current channels for digital signal processing when pins "<b>IBP</b>" and "<b>IBN</b>" are used.</p> <p>1: Current IA is sent to Measurement Channel for the processing; Current IB is sent to Current Channel for the processing.</p> <p>0: Current IA is sent to Current Channel for the processing; Current IB is sent to Measurement Channel for the processing.</p>

The signal output from ADCs must be input to a phase compensation circuit to correct the phase error between the current and voltage signal introduced by the mismatch of the transformers and ADCs.

## 6.4. Phase Compensation

A phase compensation circuit composed of a chain of time-delay units is applied to correct the phase error between the current and voltage signals. Either the current or voltage signal can be selected to be delayed via the bit "PHCIU" ("bit18" of "MTPARA1", 0x0184). The phase compensation resolution is 0.0055°/lsb, and the maximum phase error correction range is ±1.4°.

**Table 6-5 Registers for phase compensation**

Register	Bit	Default	Description
MTPARA1 0x0184	Bit19 ENPHC	0	Set this bit to '1' to enable phase compensation. By default this function is disabled.
	Bit18 PHCIU	0	Set this bit to '1' to delay voltage for phase compensation. Clear this bit to delay current for phase compensation.
	Bit[15:8] PHC	0	To set the absolute value for phase compensation. By default the resolution is 0.0055°/lsb, and a phase error of up to 1.4° can be calibrated.

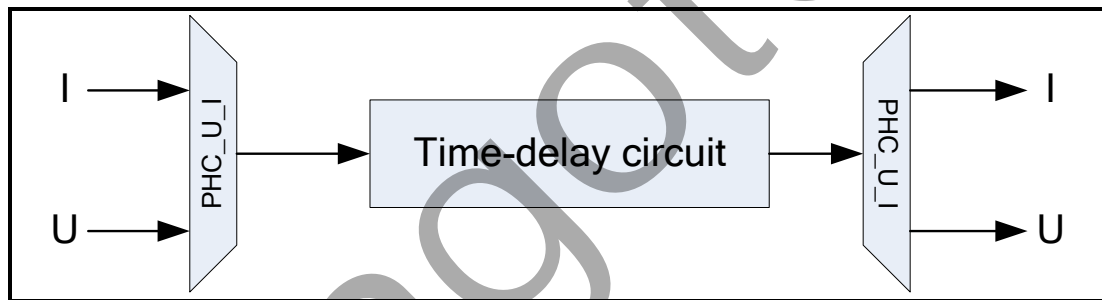

**Figure 6-5 Phase Compensation**

Compensate the phase error at power factor of 0.5L:

$$N = \text{Round} \left( \frac{3011}{2} \times E \times \frac{f_{\text{smp}}}{819200} \right) \quad \text{Equation 6-2}$$

where

$N$  is the value to be set in bit[15:8] of register MTPARA1 (0x0184);

$E$  is the error displayed in LCD screen of the calibration equipment.

$f_{\text{smp}}$  is determined by the configuration of MEACLKSEL bits (Bit1, SysCtrl, 0x0180).

**Table 6-6 Resolution and correction range at different frequencies**

N value	configure		$f_{\text{smp}}$ (Hz)	resolution (°/lsb)	correction range (°)
[-255, +255]	CKMDIV bit1, 0x0180	0	3276800	0.005	1.4
		1	819200	0.022	5.6

## 6.5. Digital Input and DC Removalment

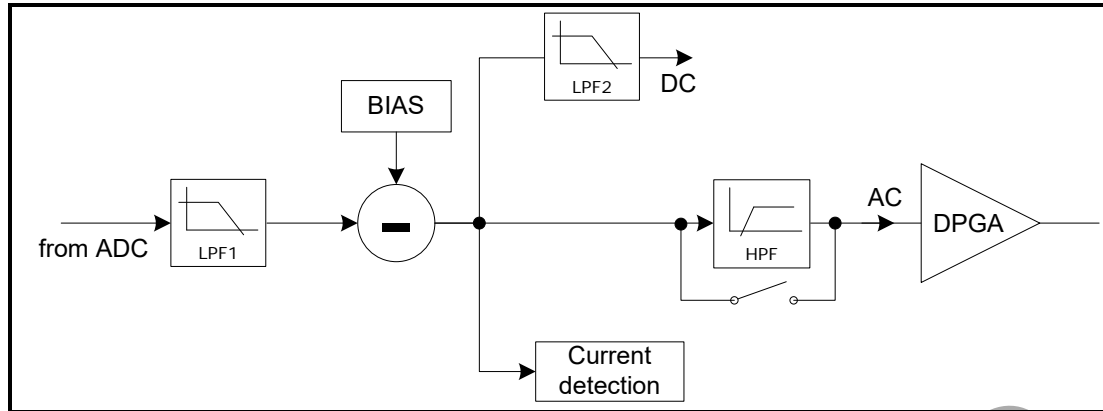

**Figure 6-6 Digital Input and DC Removalment (Current Signal is Taken as an Example.)**

The 1-bit code stream output from the oversampling  $\Sigma/\Delta$ ADC can be enabled to be sent to the decimation filter to suppress the high-frequency noise and to lower the sampling frequency to get the raw waveform of each signal. The raw waveform is transferred to a subtractor to remove the direct drift introduced by the external components and ADCs, with the help of the DC bias preset in registers **"ZZDCI"** (0x0123) and **"ZZDCU"** (0x0124). Then, the signals are processed as follows:

- The signals are transferred to the low-pass filter **"LPF2"** to obtain the DC components of the signals that can be read out from registers for DC components located at **"DCI"** (0x0114) and **"DCU"** (0x0115).
- By default the signals are transferred to a high-pass filter **"HPF"** to remove the DC components of the raw waveforms and obtain the AC components to calculate the power and RMS.
- In Channel I, the current signal is transferred for the current detection. Please refer to **"Current Detection Interrupt"** for the detailed information.

The registers for DC components of voltage and current, located at addresses of **"0x0114"** and **"0x0115"**, are in the format of 32-bit 2' complement. When the **"MEACLK"** frequency is 3.2768 MHz, the data will be updated in 160 ms and settled in 300 ms; when the **"MEACLK"** frequency is 819.2 kHz, the data will be updated in 640 ms and settled in 1200 ms. The signal input to the decimation filter is enabled or disabled via configuring **"bit[17:16]"** of **"MTPARA1"** (0x0184). When this function is enabled, the code stream will be accumulated to the filter; when this function is disabled, a constant '0' will be input for the digital signal processing. Users can disable this HPF via configuring the bit **"BPHPF"** (**"bit20"** of **"MTPARA1"**, 0x0184).

**Table 6-7 Enable/Disable Digital Inputs**

Register	Bit	Description
MTPARA1 0x0184	Bit17 ONI	To enable digital signal input of current channel for digital signal processing 1: Enable. 0: Disable. When this bit is cleared, a constant '0' is input for digital signal processing.
	Bit16 ONU	To enable digital signal input of voltage channel for digital signal processing 1: Enable

Register	Bit	Description
		0: Disable. When this bit is cleared, a constant '0' will be input for the digital signal processing.

Digital Programmable Gain Amplifiers (DPGA) with possible gain selection of 1/32~32, via "MTPARA1" (0x0184), are applied to digital signals output from the high-pass filter to amplify the signals. The product of the signal and PGA gains (Including digital and analog PGA) must be no higher than the voltage reference.

**Table 6-8 DPGA Gain Selection for Digital Signals**

Register	Bit	Default	Description
MTPARA1 0x0184	Bit[7:4] PGAI	0	To set digital PGA gain of current input 0000: ×1; 0001: ×1/2; 0010: ×1/4; 0011: ×1/8; 0100: ×1/16; 0101: ×1/32; 1000: ×1; 1001: ×2; 1010: ×4; 1011: ×8; 1100: ×16; 1101: ×32.
	Bit[3:0] PGAU	0	To set digital PGA gain of voltage input 0000: ×1; 0001: ×1/2; 0010: ×1/4; 0011: ×1/8; 0100: ×1/16; 0101: ×1/32; 1000: ×1; 1001: ×2; 1010: ×4; 1011: ×8; 1100: ×16; 1101: ×32.

Equation 6-3 depicts the signal processing:

$$\begin{aligned}
 U &= PGAd_u \times \frac{PGA_u \times A_u \times \sin \omega t}{1.188} \\
 I &= PGAd_i \times \frac{PGA_i \times A_i \times \sin(\omega t + \phi)}{1.188}
 \end{aligned}$$

Equation 6-3

Where,

*PGAd<sub>u</sub>* and *PGAd<sub>i</sub>* are the DPGA gains.

*PGA<sub>u</sub>* and *PGA<sub>i</sub>* are the APGA gains.

*A<sub>u</sub>* and *A<sub>i</sub>* are the amplitude of current and voltage inputs.

1.188 is the reference voltage.

## 6.6. RMS Calculation

The alternating component (AC) of the current and voltage can be used for:

1. The total current and voltage RMS calculation directly
2. The fundamental current and voltage RMS calculation after being processed by the low-pass filter "BPF" that introduces a gain of 0.85197

The values of the total current and voltage RMS are acquired from the following equations:

$$I_{rms} = \frac{\sqrt{2}}{2} \times 0.99992 \times PGAdi \times \frac{PGAi \times Ai}{1.188} \quad \text{Equation 6-4}$$

$$U_{rms} = \frac{\sqrt{2}}{2} \times 0.99992 \times PGAdu \times \frac{PGAu \times Au}{1.188} \quad \text{Equation 6-5}$$

And the fundamental current and voltage RMS are acquired from the following equations:

$$BI_{rms} = \frac{\sqrt{2}}{2} \times 0.85197 \times PGAdi \times \frac{PGAi \times Ai}{1.188} \quad \text{Equation 6-6}$$

$$BU_{rms} = \frac{\sqrt{2}}{2} \times 0.85197 \times PGAdu \times \frac{PGAu \times Au}{1.188} \quad \text{Equation 6-7}$$

Where,

*PGAdi* and *PGAdu* are the digital PGA gains of current and voltage.

*PGAi* and *PGAu* are the analog PGA gains of current and voltage.

*Ai* and *Au* are the amplitude of current and voltage inputs.

1.188 is the reference voltage.

0.99992 and 0.85197 are the gains introduced by the filters.

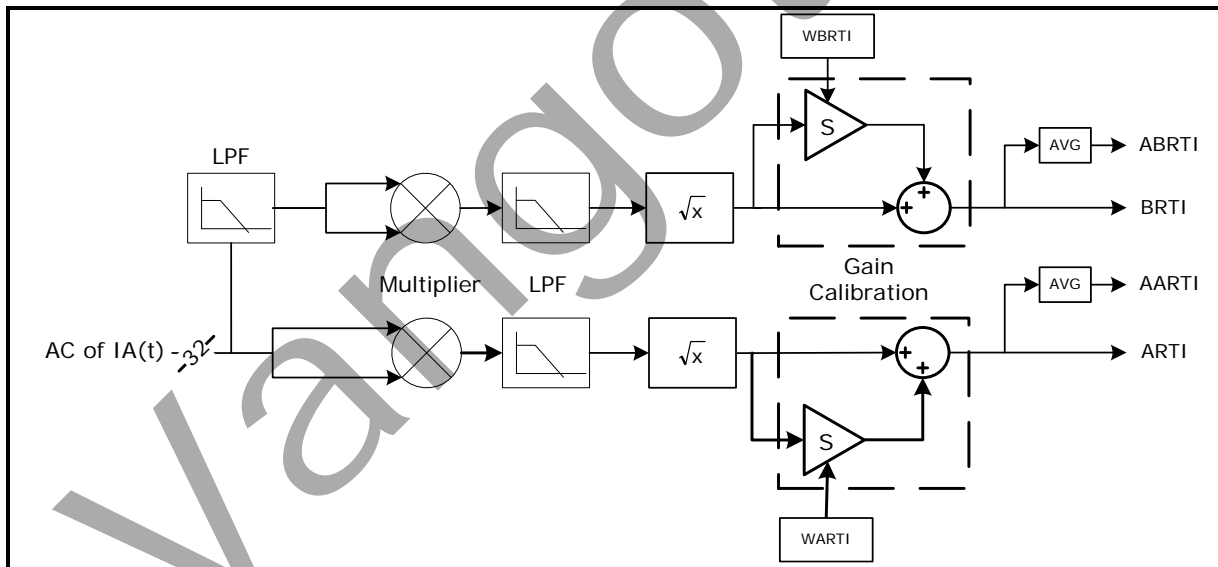

Figure 6-7 Total / Fundamental RMS Calculation

The current or voltage RMS calculated via the above equations must be gain calibrated, as depicted in the following equation:

$$RMS = RMS' \times (1 + S) \quad \text{Equation 6-8}$$

Where,

*RMS'* is the raw current or voltage RMS, calculated via the above equations.

*RMS* is the current or voltage RMS after calibration.

*S* is the gain calibration, set in registers located at addresses "0x012C", "0x0132", "0x0126", and "0x012B".

After gain calibration, the instantaneous RMS, which will be averaged to obtain the average RMS, is stored in the registers for total/fundamental current/voltage RMS. All the registers are in the format of 32-bit 2'-complement.

When the "MEACLK" frequency is 3.2768 MHz, registers for raw and instantaneous RMS will be updated in 160 ms and settled in 500 ms; and registers for average RMS will be updated in 1.28 s and settled in 3 s.

When the "MEACLK" frequency is 819.2 kHz, registers for raw and instantaneous RMS will be updated in 640 ms and settled in 2000 ms; and registers for average RMS will be updated in 5.12 s and settled in 12 s.

### 6.7. Power Calculation

The alternating component (AC) of the current and voltage can be used for:

1. The total active power calculation directly
2. The total reactive power calculation after a phase shift by 90 degrees via the Hilbert filter

And after being processed by the low-pass filter, the current and voltage signal are used to compute the fundamental active and reactive power.

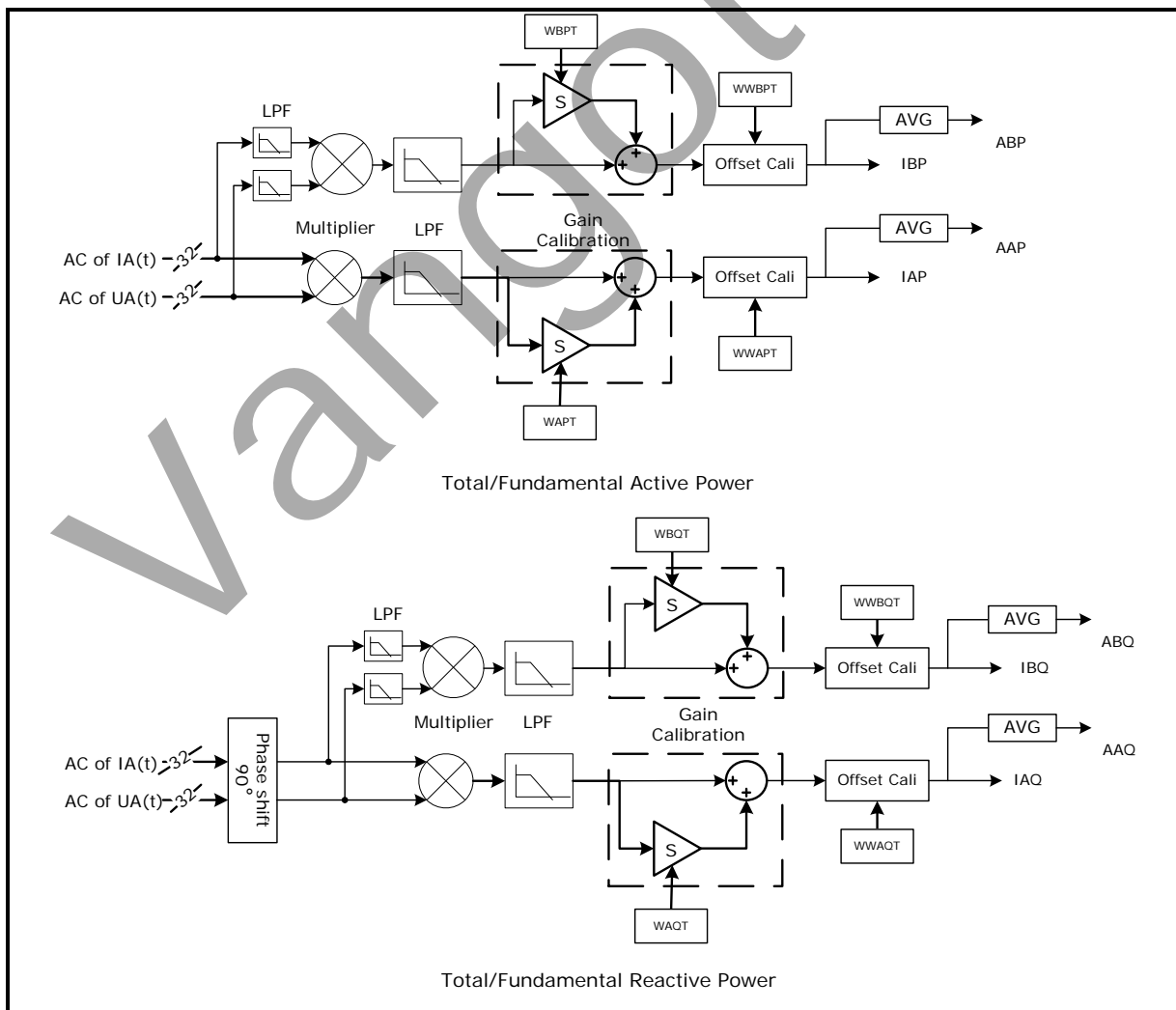

Figure 6-8 Active/Reactive Power Calculation

The total signals, including fundamental wave and harmonic wave, are used to calculate the total active and reactive power directly. The active power is acquired via the following equation:

$$P = \frac{1}{2} \times \frac{A_i \times PG_{Ai} \times PG_{Adi}}{1.188} \times \frac{A_u \times PG_{Au} \times PG_{Adu}}{1.188} \times \cos \theta \times 0.99985 \quad \text{Equation 6-9}$$

And the reactive power is acquired via the following equation:

$$Q = \frac{1}{2} \times \frac{A_i \times PG_{Ai} \times PG_{Adi}}{1.188} \times \frac{A_u \times PG_{Au} \times PG_{Adu}}{1.188} \times \sin \theta \times 0.78402 \quad \text{Equation 6-10}$$

Where,

$PG_{Adi}$  and  $PG_{Adu}$  are digital PGA gains of current and voltage.

$PG_{Ai}$  and  $PG_{Au}$  are analog PGA gains of current and voltage.

$A_i$  and  $A_u$  are the amplitude of current and voltage inputs.

$\theta$  is the phase difference between voltage and current signals.

0.99985 and 0.78402 are the gains introduced by the filters.

Filtered by the band-pass filter, the signals are used to calculate the fundamental active and reactive power.

$$\text{Fundamental active power: } BP = \frac{1}{2} \times \frac{A_i \times PG_{Ai} \times PG_{Adi}}{1.188} \times \frac{A_u \times PG_{Au} \times PG_{Adu}}{1.188} \times \cos \theta \times 0.72585 \quad \text{Equation 6-11}$$

$$\text{Fundamental reactive power: } BQ = \frac{1}{2} \times \frac{A_i \times PG_{Ai} \times PG_{Adi}}{1.188} \times \frac{A_u \times PG_{Au} \times PG_{Adu}}{1.188} \times \sin \theta \times 0.36292 \quad \text{Equation 6-12}$$

Where,

$PG_{Adi}$  and  $PG_{Adu}$  are digital PGA gains of current and voltage.

$PG_{Ai}$  and  $PG_{Au}$  are analog PGA gains of current and voltage.

$A_i$  and  $A_u$  are the amplitude of current and voltage inputs.

$\theta$  is the phase difference between voltage and current signals.

0.72585 and 0.36292 are the gains introduced by the filters.

The active or reactive power must be gain and offset calibrated, as depicted in the following equation,

$$P = P' \times (1 + S) + C \quad \text{Equation 6-13}$$

Where,

$P'$  is the raw active or reactive power calculated via the above equations.

$P$  is the active or reactive power after calibration.

$S$  is the gain calibration set in the registers.

$C$  is the offset calibration set in the registers.

After gain and offset calibration, the instantaneous active and reactive power, which will be averaged to obtain the average active and reactive power, is stored in the total and fundamental active/reactive power registers. All the registers are in the format of 32-bit 2'-complement.

When the **"MEACLK"** frequency is 3.2768 MHz, registers for the raw and instantaneous power will be updated in 160 ms and settled in 500 ms; and registers for the average power will be updated in 1.28 s and settled in 3 s.

When the **"MEACLK"** frequency is 819.2 kHz, registers for the raw and instantaneous power will be updated in 640 ms and settled in 2000 ms; and registers for the average power will be updated in 5.12 s and settled in 12 s.

## 6.8. Energy Accumulation and CF Pulse Output

V9261F supports the energy accumulation and converting the energy into pulses. By default this function is disabled. Users can set the bit **"EGYEN"** (**"bit30"** of **"MTPARA0"**, 0x0183) to '1' to enable the energy accumulation and energy-to-pulse conversion.

In the Vango metering architecture, configure the bit **"ENGSEL"** (**"bit[23:22]"** of **"MTPARA0"**, 0x0183) to select an average power to transfer to the register **"DATACP"** (0x0189). The content of this register will be accumulated to the positive or negative energy accumulator (**"PEGY"** at 0x01A1 and **"NEGY"** at 0x01A2) depending on the sign. When the **"MEACLK"** frequency is 3.2768 MHz, the accumulation frequency will be 204.8 kHz; when the **"MEACLK"** frequency is 819.2 kHz, the accumulation frequency will be 102.4 kHz.

Clear bit **"CKSUM"** (**"bit22"** of **"MTPARA1"**, 0x0184) and set bit **"IDET"** (**"bit21"** of **"MTPARA"**, 0x0184) to '1' to force the Vango metering architecture to compute for the configuration verification and current detection. In this condition, write a value to register **"DATACP"** (0x0189) for the energy accumulation based on the constant.

Preset a threshold in the register **"EGYTH"** (0x0181). When the content of energy accumulator is higher than the preset threshold, the energy accumulator will overflow, and a value equal to the threshold will be subtracted from the energy accumulator. An energy pulse is generated and the CF pulse counter increments by '1' every two accumulator overflows.

Please note that the CF pulse generation circuit is an independent functional unit. So users must set the bit **"CLKSEL"** (**"bit28"** of **"MTPARA0"**, 0x0183) to inform the CF pulse generation circuit to work at the set **"MEACLK"** frequency.

When a low signal is input, users can reduce the energy threshold to increase the pulse generation rate to quicken the energy calibration via configuring bits **"CFFAST"** (**"bit[25:24]"** of **"MTPARA0"**, 0x0183).

When the power-down interrupt occurs, the latch of **"PDN"**, **"RPDN"** (bit22,0x0180) is set to '1'. If **"CF PROT"** (Bit7,0x0183) is set to '1', the output of CF will be fixed as '0'. And the energy counter/CF counter will remain operating to realize the under-voltage protection of CF output.

When the power-down event disappears, **PDN** will become '0', **RPDN** will remain '1', and CF output will be '0'. At the same time, resetting the chip or any write operation to "0x0180" can set **"RPDN"** to '0'. The CF output will restore to the normal state.

Set the bit **"CFEN"** (**"bit31"** of **"MTPARA0"**, 0x0183) to '1' to enable the CF pulse output on the pin **"CF"**. When the **"MEACLK"** frequency is 3.2768 MHz, the maximum CF pulse output frequency will be 102.4 kHz, and the normal pulse width will be 80 ms. If a pulse width is less than 160 ms, pulses of 50% duty cycles will be output.

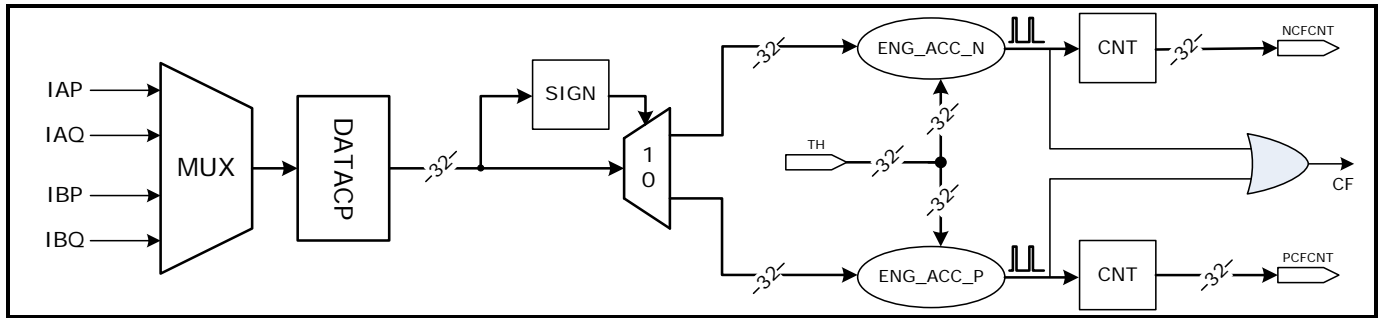

Figure 6-9 Energy Accumulation and CF Pulse Output

Table 6-9 Registers for Energy Accumulation and CF Pulse Output

Register	Bit	Default	Description
0x0183 MTPARA0	Bit31 CFEN	0	Set this bit to '1' to enable CF pulse output. By default this function is disabled, and the pin "CF" outputs "logic 0".
	Bit30 EGYEN	0	Set this bit to '1' to enable energy accumulation and energy-to-pulse conversion. By default this function is disabled.
	Bit28 CLKSEL	0	When the "MEACLK" frequency is 3.2768 MHz, clear this bit to inform the CF pulse generation circuit to work at 3.2768 MHz. When the "MEACLK" frequency is 819.2 kHz, set this bit to '1' to inform the CF pulse generation circuit to work at 819.2 kHz.
	Bit[27:26] CFSEL	0	To select the energy to be converted into CF pulse 01: Positive energy 10: Negative energy 00/11: The sum of the positive and negative energy
	Bit[25:24] CFFAST	0	To accelerate the CF pulse generation rate 00: x1 01: x4 10: x8 11: x16
	Bit[23:22] ENGSEL	0	To select the power for energy accumulation 00: Instantaneous total active power 01: Instantaneous total reactive power 10: Instantaneous fundamental active power 11: Instantaneous fundamental reactive power
0x0189	DATACP	0	Select the power and transfer it to this register as the source for energy accumulation.

Register	Bit	Default	Description
DATA CP			
0x0181 EGYTH	EGYTH	0	Set a threshold for energy-to-pulse conversion.

## 6.9. No-Load Detection

V9261F supports the no-load detection. By default this function is disabled, but users can enable it via configuring the bit **"CRPEN"** (**"bit29"** of **"MTPAR00"**, 0x0183).

There is an anti-creeping accumulator in the no-load detection circuit. When the no-load detection is enabled, 1s will be accumulated in this accumulator constantly at the same frequency of the energy accumulation.

When the no-load detection is enabled, the constant 1s will be accumulated into the embedded anti-creeping accumulator, and the energy accumulators will accumulate the content of register **"DATA CP"** (0x0189). Preset a threshold for the no-load detection in the register **"CTH"** (0x0182), and a threshold for energy-to-pulse conversion in the register **"EGYTH"** (0x0181). Compare the accumulation rate. If the energy accumulator overflows sooner, the anti-creeping accumulator will be cleared, and the Vango metering architecture will start to meter the energy. Otherwise, the Vango metering architecture will enter the creeping state. Users can read the bit **"CFCRP"** (**"bit31"** of **"SysCtrl"**, 0x0180) to detect the state.

The threshold register for the no-load detection are of actual 32-bit length. It will be padded with a string of 4 0s on the right to work as a 36-bit register.

**Table 6-10 Registers and Bits for No-Load Detection**

Register	Bit	Default	Description
0x0183 MTPARA0	Bit29 CRPEN	0	Set this bit to '1' to enable no-load detection. By default this function is disabled.
0x0180 SysCtrl	Bit31 CFCRP	0	To indicate the state of the system 0: Metering energy 1: Creeping
0x0182 CTH		0	Set a threshold for no-load detection.

## 6.10. Line Frequency Measurement

V9261F supports the line frequency measurement.

In the line frequency measurement circuit, the fundamental voltage signal is sampled at a frequency of 3200 Hz for the negative-to-positive zero-crossing detection, and the number of the samples among

two continuous negative-to-positive transitions is equal to the instantaneous line frequency. So the instantaneous line frequency is calculated as follows:

$$f = \frac{3200}{\text{FREQ}} \quad \text{Equation 6-14}$$

Where,  $f$  is the line frequency to be measured; FREQ is the content of the instantaneous line frequency register (0x019A), in the form of decimal.

The instantaneous line frequency will be accumulated 256 times every 1.28 s to be averaged to acquire the average line frequency per second:

$$f' = \frac{3200 \times 256}{\text{ASFREQ}} \quad \text{Equation 6-15}$$

Where,  $f'$  is the line frequency to be measured; ASFREQ is the average line frequency per second read out of the register (0x011D), in the form of decimal.

To improve the measurement accuracy, the above average line frequency per second will be accumulated 8 times every 10.24 s to be averaged to acquire the average line frequency:

$$f'' = \frac{3200 \times 256 \times 8}{\text{AFREQ}} \quad \text{Equation 6-16}$$

Where,  $f''$  is the line frequency to be measured; AFREQ is the average line frequency read out of the register (0x011E), in the form of decimal.

In V9261F, a band-pass filter is applied to remove the direct component, the noise and the harmonic wave of the voltage signal to obtain the fundamental voltage for line frequency measurement. The performance of the band-pass filter is affected by the number of bits to be shifted and the filter coefficient. When fewer bits are shifted, the filter needs less time to respond, is less sensitive to the frequency deviation, and has less capability to depress the noise and harmonics.

**Table 6-11 Bandpass Filter Parameters**

Group	Shift bits (0x0183, MTPARA0)		Bandpass filter coefficient	Frequency deviation	
	BPFSFT, bit[14:13]	Bits to be shifted	BPF PARA, 0x0125	47.5Hz(db)	150Hz(db)
0	00	>>8	0x811D2BA7	-4.2	-30.5
1	01	>>9	0x80DD7A8C	-8.9	-36.5
2	10	>>10	0x80BDA1FE	-14.1	-42.6
3	11	>>11	0x80ADB5B8	-20	-48.6

Generally, Group 0 is preferred.

## 6.11. Measuring Various Signals in M Channel

The M Channel can be used to measure the current, ground, and temperature. As illustrated in Figure 6-10, there is only one ADC in the M Channel, so users must configure registers to use this channel

to measure one signal at a time.

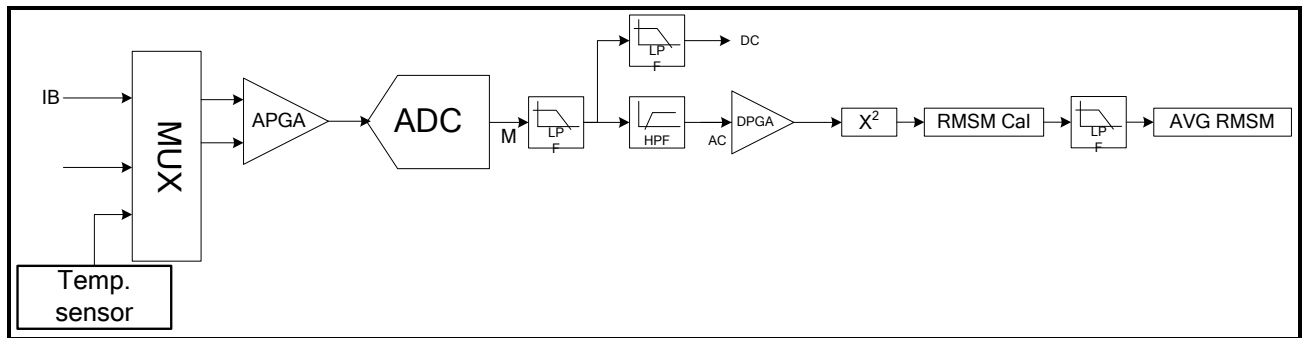

Figure 6-10 Signal Processing in M Channel

Table 6-12 Registers for M Channel Configuration

Register	Bit	Default	Description
0x0185 ANCtrl0	Bit25 ADCMPPDN	0	Set this bit to '1' to enable Measurement Channel ADC. The Bandgap circuit must be enabled before this ADC.  Both in the Sleep Mode and Current Detection Mode, this bit is cleared automatically.
	Bit[5:4] GM<1:0>	0	To set analog PGA gain of analog input of Measurement Channel ADC The analog PGA gain is determined by the output signal of the sensor. The product of the output signal and PGA gain (Both analog and digital) must be no more than the voltage reference.  00: ×4 01: ×1 10: ×32 11: ×16
0x0184 MTPARA1	Bit[31:28] PGAM	0	To set digital PGA gain for various signal input of Measurement Channel 0000: ×1; 0001: ×1/2; 0010: ×1/4; 0011: ×1/8; 0100: ×1/16; 0101: ×1/32;  1000: ×1; 1001: ×2; 1010: ×4; 1011: ×8; 1100: ×16; 1101: ×32.
	Bit27 ONM	0	To enable digital signal input of Measurement Channel for digital signal processing  1: Enable  0: Disable. When this bit is cleared, a constant '0' will be input for the digital signal processing.

Register	Bit	Default	Description
	Bit26 SELI	0	To select current channels for digital signal processing when pins <b>"IBP"</b> and <b>"IBN"</b> are used  1: Current IA is sent to Measurement Channel for processing; current IB is sent to Current Channel for processing.  0: Current IA is sent to Current Channel for processing; Current IB is sent to Measurement Channel for processing.
	Bit25 CIB	0	Set this bit to <b>'1'</b> to enable digital signal processing in Measurement Channel.  By default this function is disabled.
0x0180 SysCtrl	Bit[7:5] MEAS	0	To select the analog input for signal processing in Measurement Channel ADC.  000: Current input on pins <b>"IBP"/"IBN"</b> 001/010/011: Reserved 100: Temperature 101/110/111: Ground
0x0186 ANCtrl1	Bit[22:20] MEAS	0	To select the analog input for signal processing in Measurement Channel ADC  000: Current input on pins <b>"IBP"/"IBN"</b> 001/010/011: Reserved 100: Temperature 101/110/111: Ground  The setting of <b>"bit[22:20]"</b> must match the <b>"MEAS"</b> (Bit[7:5]) setting in <b>"SysCtrl"</b> (0x0180).

**Table 6-13 Data Registers for M Channel**

Register	Description
0x0116 DCM	The DC component of various signals processed in M Channel  When the <b>"MEACLK"</b> frequency is 3.2768 MHz, this register will be updated in 160 ms, and settled in 300 ms.  When the <b>"MEACLK"</b> frequency is 819.2 kHz, this register will be updated in 640 ms and settled in 1200 ms.
0x00F9 DCIM	When the M Channel is used to process the current signal input from pins <b>"IBP"/"IBN"</b> or <b>"IAP"/"IAN"</b> , this register <b>"DCM"</b> (0x0116) will be the backup of the content of register <b>"DCM"</b> (0x0116), and the master MCU should read this register for the measurement.

Register		Description
0x0101	DCTM	When Measurement Channel (M) is used to measure temperature, this register will be the backup of the content of register "DCM" (0x0116), and the master MCU should read this register for the measurement.
0x0106	ARRTM	The raw RMS value of the various signal of Measurement Channel When the "MEACLK" frequency is 3.2768 MHz, the register will be updated in 160 ms and settled in 500 ms. When the "MEACLK" frequency is 819.2 kHz, the register will be updated in 640 ms and settled in 2000 ms.
0x010F	ARTM	The instantaneous RMS value of the various signal of Measurement Channel When the "MEACLK" frequency is 3.2768 MHz, the register will be updated in 160 ms and settled in 500 ms. When the "MEACLK" frequency is 819.2 kHz, the register will be updated in 640 ms and settled in 2000 ms.
0x00F8	ARTIM	When Measurement Channel (M) is used to process the current signal input from pins "IBP"/"IBN" or "IAP"/"IAN", this register will be the backup of the content of register "ARTM" (0x010F), and the master MCU should read this register for the measurement.
0x0100	ARTMM	When Measurement Channel (M) is used to measure temperature, this register will be the backup of the content of register "ARTM" (0x010F), and the master MCU should read this register for the measurement.
0x0117	AARTM	The average RMS value of the various signal of Measurement Channel When the "MEACLK" frequency is 3.2768 MHz, the register will be updated in 1.28 s and settled in 3 s. When the "MEACLK" frequency is 819.2 kHz, the register will be updated in 5.12 s and settled in 12 s.

## 6.12. Calibration

### 6.12.1. Registers for Meter Calibration

Table 6-14 Registers for Meter Calibration

Address	Register		R/W	Format
0x011B	AARTU	The average total voltage RMS	R/W	32-bit 2'-complement
0x011C	AARTI	The average total current RMS	R/W	32-bit 2'-complement
0x0121	ABRTU	The average fundamental voltage RMS	R/W	32-bit 2'-complement
0x0122	ABRTI	The average fundamental current RMS	R/W	32-bit 2'-complement
0x0119	AAP	The average total active power	R/W	32-bit 2'-complement
0x011A	AAQ	The average total reactive power	R/W	32-bit 2'-complement

Address	Register		R/W	Format
0x011F	ABP	The average fundamental active power	R/W	32-bit 2'-complement
0x0120	ABQ	The average fundamental reactive power	R/W	32-bit 2'-complement
0x012C	WARTI	Set a value to gain calibrate the total current RMS.	R/W	32-bit 2'-complement
0x0132	WARTU	Set a value to gain calibrate the total voltage RMS.	R/W	32-bit 2'-complement
0x0126	WBRTI	Set a value to gain calibrate the fundamental current RMS.	R/W	32-bit 2'-complement
0x012B	WBRTU	Set a value to gain calibrate the fundamental voltage RMS.	R/W	32-bit 2'-complement
0x012E	WAPT	Set a value to gain calibrate the total active power.	R/W	32-bit 2'-complement
0x0130	WAQT	Set a value to gain calibrate the total reactive power.	R/W	32-bit 2'-complement
0x012F	WWAPT	Set a value to offset calibrate the total active power.	R/W	32-bit 2'-complement
0x0131	WWAQT	Set a value to offset calibrate the total reactive power.	R/W	32-bit 2'-complement
0x0127	WBPT	Set a value to gain calibrate the fundamental active power.	R/W	32-bit 2'-complement
0x0129	WBQT	Set a value to gain calibrate the fundamental reactive power.	R/W	32-bit 2'-complement
0x0128	WWBPT	Set a value to offset calibrate the fundamental active power.	R/W	32-bit 2'-complement
0x012A	WWBQT	Set a value to offset calibrate the fundamental reactive power.	R/W	32-bit 2'-complement
0x0181	EGYTH	Set a threshold for energy-to-pulse conversion.	R/W	32-bit 2'-complement
0x0182	CTH	Set a threshold for no-load detection.	R/W	32-bit 2'-complement
0x0117	AARTM	The average current RMS value of the various signal of M Channel when it is used for current measurement	R/W	32-bit 2'-complement
0x012D	WARTM	Set a value to gain calibrate the RMS value of various signal in M Channel.	R/W	32-bit 2'-complement

## 6.12.2. Equations for Calibration

### 1. Equation for current/voltage RMS registers

$$\text{Value} = V \times G \times K$$

$$\text{Equation 6-17}$$

Where,  $V$  is the RMS value of the input signal;  $G$  is the gain; and  $K$  is a coefficient,  $1.486 \times 10^9$  for

fundamental RMS and  $1.745 \times 10^9$  for total RMS.

## 2. Equation for active power registers.

$$P = Vi \times Gi \times Vv \times Gv \times Bp \times \cos\theta \quad \text{Equation 6-18}$$

Where,  $Vi$  and  $Vv$  are the input current and voltage;  $Gi$  and  $Gv$  are the analog PGA gains for current and voltage respectively;  $\cos\theta$  is the power factor;  $Bp$  is a coefficient,  $1.419 \times 10^9$  for total active power and  $1.030 \times 10^9$  for fundamental active power.

## 3. Equation for reactive power registers

$$Q = Vi \times Gi \times Vv \times Gv \times Bq \times \sin\theta \quad \text{Equation 6-19}$$

Where,  $Vi$  and  $Vv$  are the input current and voltage;  $Gi$  and  $Gv$  are the analog PGA gains for current and voltage respectively;  $\theta$  is phase difference between current and voltage;  $Bq$  is a coefficient,  $1.111 \times 10^9$  for total reactive power and  $0.514 \times 10^9$  for fundamental reactive power.

## 4. Equation for ratio of RMS and power

The value acquired by Equation 6-17, Equation 6-18, or Equation 6-19 is the theoretical value of the register of RMS or power. It must be multiplied by a ratio to get the actual value (Accurate to the second decimal place).

$$D = \frac{Vn}{\text{Value}} \quad \text{Equation 6-20}$$

Where,  $Value$  is the theoretical value of the registers acquired by Equation 6-17, Equation 6-18, or Equation 6-19;  $D$  is the ratio; and  $Vn$  is the rated voltage/current/power.

## 5. Equation for registers for phase compensation

Compensate the phase error at power factor of 0.5L:

$$N = \text{Round} \left( \frac{3011}{2} \times E \times \frac{fsmpl}{819200} \right) \quad \text{Equation 6-21}$$

Where

$N$  is the value to be set in bit[15:8] of register MTPARA1 (0x0184);

$E$  is the error displayed in LCD screen of the calibration equipment.

$fsmpl$  is determined by the configuration of MEACLKSEL bits (Bit1, SysCtrl, 0x0180).

## 6. Equation for energy pulse conversion threshold

$$PGAT = P' \times T \times \frac{1}{2} \times \frac{204800}{2^{14}} = P' \times T \times 6.25 \quad \text{Equation 6-22}$$

Where,  $P'$  is the power calculated by Equation 6-18 or Equation 6-19;  $T$  is a time constant acquired via Equation 6-23:

$$T = \frac{3600 \times 1000}{\text{PulseConstant} \times Un \times Ip} \quad \text{Equation 6-23}$$

**7. Equation for gain calibration registers**

$$S = 2^{31} \left( \frac{1}{1+e} - 1 \right) + S_1 \left( \frac{1}{1+e} \right) \quad \text{Equation 6-24}$$

Where,  $S$  is the content to be set in the registers for gain calibration of active/reactive power or current/voltage RMS, in the form of  $2'$ -complement;  $S_1$  is the original value of the registers;  $e$  is the error: when this equation is used for the power gain calibration,  $e$  is equal to the error displayed on the LCD screen of the calibration equipment ( $E$ ); when this equation is used for the RMS gain calibration,  $e$  is equal to the error ( $E_u/E_i$ ) calculated by Equation 6-25 and Equation 6-26:

$$E_u = \frac{U_1 - U_n}{U_n} \quad \text{Equation 6-25}$$

$$E_i = \frac{I_1 - I_b}{I_b} \quad \text{Equation 6-26}$$

Where,  $U_1/I_1$  is the voltage/current RMS displayed on the LCD screen of the meter to be calibrated,  $U_n$  is the rated voltage, and  $I_b$  is the base current.

**8. Equation for power offset calibration registers**

$$C = -E \times P \times a\% \quad \text{Equation 6-27}$$

Where,  $E$  is the error displayed on the LCD screen when  $a\%I_b$  are applied at power factor 1.0; and  $P$  is value calculated via Equation 6-18.

**9. Equation for no-load detection threshold register**

$$\text{GATECP} = T \times \frac{1}{2} \times \frac{204800}{2^4} = \frac{3600 \times 1000}{U_n \times \frac{1}{2} I_s \times \text{PulseConstant}} \times 6400 \quad \text{Equation 6-28}$$

Where,  $U_n$  is the rated voltage;  $I_s$  is the starting current, equal to  $0.4\%I_b$  generally. A half of  $I_s$  is defined to detect no-load.

**6.12.3. Calibration Steps**

**6.12.3.1. Parameters Configuration**

Users must configure the following parameters when designing an energy meter:

- Parameters for a meter, including basic current, rated voltage, pulse constant, and accuracy class
- Parameters for design, including the current and voltage RMS when rated current and rated voltage are applied
- The analog PGA gains of the current and voltage channels
- The ratio (D) of RMS and power calculated via Equation 6-20.
- The threshold for energy pulse generation calculated via Equation 6-22.

- The threshold for no-load detection calculated via Equation 6-28.

When the above parameters are set, no changes should be done to them.

### 6.12.3.2. Calibrating Active Energy

#### 1. Gain calibration (Take total active power for example)

For example, at power factor of 1.0, apply 100%  $I_b$  and 100%  $U_n$  to the calibration equipment.

Get the gain calibration value of the power data ( $E$ ), and read the value of the gain calibration register WAPT (0x012E), (the raw value for gain calibration,  $S_1$ ) and then calculate the value for gain calibration via Equation 6-24 and write it to the register WAPT (0x012E).

#### 2. Phase compensation

After completing the power gain calibration, in the case of PF = 0.5L, apply 100%  $I_b$  and 100%  $U_n$  to the calibration equipment for the phase calibration.

During the gain calibration, "bit[15:8]" of register "MTPARA1" (0x0184) must be cleared first. Get the gain calibration value of the power data ( $E$ ), calibrate the values of phase compensation according to Equation 6-21, and write to the corresponding bit of the register.

#### 3. Power offset calibration (optional)

PF = 1.0, 5%  $I_b$  (usually, 2%  $I_b$ ) and 100%  $U_n$  are applied to the calibration equipment. Get the gain calibration value of the power data ( $E$ ). The offset calibration values calculated according to Equation 6-27

### 6.12.3.3. Calibrating Current RMS

1. Clear the registers "WARTI" (0x012C) or "WBRTI" (0x0126).
2. Apply 100% $I_b$  to the calibration equipment at power factor 1.0.
3. Read the current RMS " $I_1$ " shown on the LCD screen of the calibration equipment (" $I_1$ " is the product of the value of RMS registers and the coefficient "D").
4. Calculate the value to gain calibrate current RMS via Equation 6-24.

Note: When the current through the energy meter is less than the starting current, the current RMS " $I_1$ " will not be shown on the LCD screen.

### 6.12.3.4. Calibrating Voltage RMS

1. Clear the registers "WARTU" (0x0132) or "WBRTU" (0x012B)
2. Apply 100% $U_n$  to the calibration equipment
3. Read the voltage RMS " $U_1$ " shown on the LCD screen of the calibration equipment (" $U_1$ " is the product of the value of RMS registers and the coefficient "D").
4. Calculate the value to gain calibrate voltage RMS via Equation 6-24.

Vangotech

## 7. UART Interface

V9261F supports the communication with the master MCU as a slave via the UART serial interface. The UART serial interface has the following features:

- Asynchronous, half-duplex communication
- A 11-bit byte, composed of 1-bit Start bit, 8-bit Data bits, 1-bit Parity bit (Odd), and 1-bit Stop bit
- Least significant bit (lsb) shifted in or out firstly when the chip receives or transmits a byte
- 4800 bps baud rate.

When a reset event, such as a POR, RX reset, or global software reset, occurs, the UART serial interface will be reset. In the Sleep Mode, the interface is idle.

### 7.1. Data Byte

The data byte received and transmitted via the UART serial interface of V9261F is composed of 11 bits, including 1-bit Start bit (Logic low), 8-bit Data bits, 1-bit odd Parity bit, and 1-bit Stop bit (Logic high), as shown in Figure 7-1. When V9261F receives or sends a data byte, the least significant bit will always be shifted in or out firstly.



Figure 7-1 Structure of an 11-Bit Data Byte

### 7.2. Baud Rate Configuration

In V9261F, "UARTCLK" is divided to generate the baud rate. When the crystal oscillation circuit works, "UARTCLK" will be sourced by "CLK1" that is accurate enough for the UART communication. When the crystal stops running, "UARTCLK" will be sourced by "CLK2" that is not accurate enough for the UART communication.

### 7.3. Communication Protocol

In the read, write, or broadcast communication, the master MCU needs a command frame that is composed of 8 data bytes to operate a 32-bit data in V9261F.



Figure 7-2 Command Frame for Read/Write/Broadcast Operation

In the read or write operation, when V9261F receives the command frame from the master MCU, it will reply to the master MCU with a respond frame of different structures. In the broadcast communication, V9261F will not reply to the master MCU to avoid the communication conflict.

Figure 7-3 depicts the timing of UART communication.

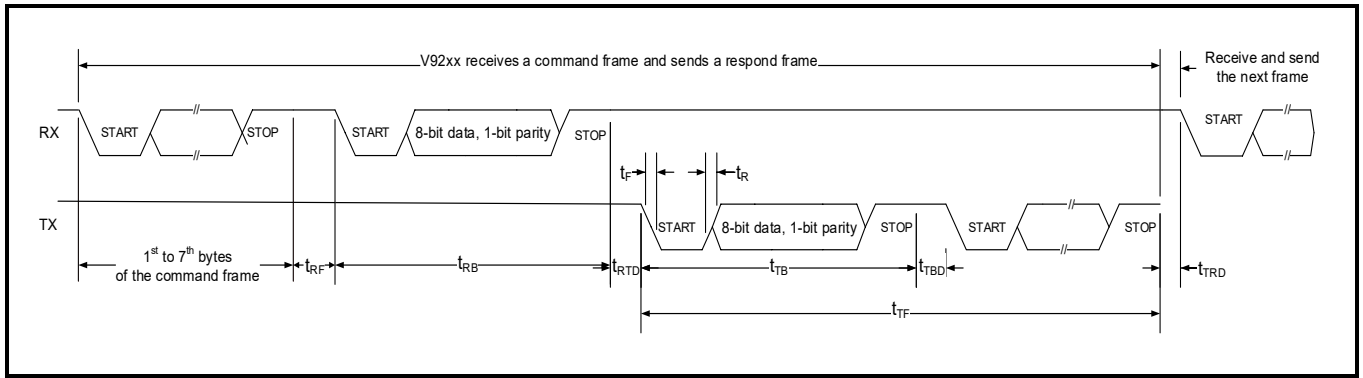

Figure 7-3 Timing of UART Communication

Table 7-1 UART Communication Timing Parameters

Parameter	Description
$t_{RB}$	Time to receive a data byte on pin "RX" $t_{RB} = \frac{11}{\text{baudrate}}$ Where, <i>baudrate</i> is the actual baud rate.
$t_{RF}$	The maximum time between two bytes when receiving a command frame on pin "RX" $t_{RF} = \frac{16}{\text{baudrate}}$ Where, <i>baudrate</i> is the actual baud rate. <i>Baudrate=4800bps</i> , $t_{RF}=3.33\text{ms}$ . After a timeout event, the UART serial interface is idle and waits for the next command frame.
$t_{RTD}$	The delay between command frame reception on pin "RX" and respond frame transmission on pin "TX". $0 \text{ ms} \leq t_{RTD} \leq 20 \text{ ms}$ Please note that no respond frame will be transmitted in the broadcast communication, and at least 2-ms delay is recommended between two continuous command frames for broadcast communications.
$t_{TF}$	Time to transmit a respond frame in read or write operation, depending on the structure of the frame
$t_{TB}$	Time to transmit a data byte $t_{TB} = \frac{11}{\text{baudrate}}$ Where, <i>baudrate</i> is the actual baud rate.
$t_{TBD}$	Delay between two continuous data bytes in a respond frame $0 \text{ ms} \leq t_{TBD} \leq 20 \text{ ms}$

Parameter	Description
t <sub>TRD</sub>	The delay between respond frame transmission on pin "TX" and the next command frame reception on pin "RX". More than 2 ms is recommended.
t <sub>R</sub>	Rising time of "RX" and "TX", about 300 ns
t <sub>F</sub>	Falling time of "RX" and "TX", about 300 ns

## 7.3.1. Write Operation

The master MCU needs a command frame, composed of 8 data bytes, to write of a 32-bit data to the register of V9261F. When it receives the command frame, V9261F will transmit a respond frame, composed of 4 data bytes, to reply to the master MCU. On both transmission and reception, the lsb is shifted in or out firstly.

**Table 7-2 Structure of Data Byte (B7:B0) From Master MCU to V9261F on Write Operation**

Order	Byte	B7	B6	B5	B4	B3	B2	B1	B0
1	Head Byte	1	1	1	1	1	1	1	0
2	Control Byte	The higher 4 bits of the target register address				0	0	1	0
3	Address Byte	The lower 8 bits of the target register address							
4	Data Byte 0	"Bit [7:0]" of the target data							
5	Data Byte 1	"Bit[15:8]" of the target data							
6	Data Byte 2	"Bit[23:16]" of the target data							
7	Data Byte 3	"Bit[31:24]" of the target data							
8	Check Byte	The checksum. Add the above 7 data bytes, invert the sum, and then add it to "0x33" to obtain the checksum.							

**Table 7-3 Structure of Data Byte (B7:B0) From V9261F to Master MCU on Write Operation**

Order	Byte	B7	B6	B5	B4	B3	B2	B1	B0
1	Head Byte	1	1	1	1	1	1	1	0
2	Control Byte	The higher 4 bits of the target register address				0	0	1	0
3	Address Byte	The lower 8 bits of the target register address							
4	Check Byte	The checksum. Add the above 3 data bytes, invert the sum, and then add it to "0x33" to obtain the checksum.							

## 7.3.2. Read Operation

The master MCU needs a command frame, composed of 8 data bytes, to read of a 32-bit data of a

register of V9261F. When it receives the command frame, V9261F will transmit a respond frame, composed of  $4 \times N + 4$  ( $1 \leq N \leq 255$ ) data bytes, to reply to the master MCU. On both transmission and reception, the lsb is shifted in or out firstly.

**Table 7-4 Structure of Data Byte (B7:B0) From Master MCU to V9261F on Read Operation**

Order	Byte	B7	B6	B5	B4	B3	B2	B1	B0
1	Head Byte	1	1	1	1	1	1	1	0
2	Control Byte	The higher 4 bits of the target register address (D <sub>1</sub> )				0	0	0	1
3	Address Byte	The lower 8 bits of the target register address (D <sub>1</sub> )							
4	Data Byte 0	<p>The length (N, in unit of "Word") of the data to be read from the registers located at the addresses beginning with the target address (D<sub>1</sub>) given by the Control Byte and Address Byte. When Data Byte 0 is '0', it means 1 data word (4 bytes) is read out.</p> <p>When the master MCU reads of the target address only, N is '1'.</p> <p>When more than one registers located at continuous addresses beginning with the target address (D<sub>1</sub>), N is equal to the number of the address. The maximum value of N is 255, which means no more than 255 continuous registers can be read at a time.</p>							
5	Data Byte 1	No actual function.							
6	Data Byte 2								
7	Data Byte 3								
8	Check Byte	The checksum. Add the above 7 data bytes, invert the sum, and then add it to "0x33" to obtain the checksum.							

**Table 7-5 Structure of Data Byte (B7:B0) From V9261F to Master MCU on Read Operation**

Order	Byte	B7	B6	B5	B4	B3	B2	B1	B0
1	Head Byte	1	1	1	1	1	1	1	0
2	Control Byte	The higher 4 bits of the target register address (D <sub>1</sub> )				0	0	0	1
3	Length Byte	N, equal to Data Byte 0 sent from master MCU to V9261F on read operation. When Data Byte 0 is '0', N is equal to '1'.							
4	Data Byte 10	"Bit[7:0]" of the register located at target address (D <sub>1</sub> )							
5	Data Byte 11	"Bit[15:8]" of the register located at target address (D <sub>1</sub> )							
6	Data Byte 12	"Bit[23:16]" of the register located at target address (D <sub>1</sub> )							
7	Data Byte 13	"Bit[31:24]" of the register located at target address (D <sub>1</sub> )							
8	Data Byte 20	"Bit[7:0]" of the register located at address D <sub>2</sub> (D <sub>2</sub> =D <sub>1</sub> +1)							
9	Data Byte 21	"Bit[15:8]" of the register located at address D <sub>2</sub> (D <sub>2</sub> =D <sub>1</sub> +1)							
...	...	...							

Order	Byte	B7	B6	B5	B4	B3	B2	B1	B0
4×N+0	Data Byte N0	"Bit[7:0]" of the register located at address D <sub>N</sub> (D <sub>N</sub> =D <sub>1</sub> +N-1)							
4×N+1	Data Byte N1	"Bit[15:8]" of the register located at address D <sub>N</sub> (D <sub>N</sub> =D <sub>1</sub> +N-1)							
4×N+2	Data Byte N2	"Bit[23:16]" of the register located at address D <sub>N</sub> (D <sub>N</sub> =D <sub>1</sub> +N-1)							
4×N+3	Data Byte N3	"Bit[31:24]" of the register located at address D <sub>N</sub> (D <sub>N</sub> =D <sub>1</sub> +N-1)							
4×N+4	Check Byte	The checksum. Add the above 4×N+3 data bytes, invert the sum, and then add it to "0x33" to obtain the checksum.							

### 7.3.3. Broadcast Communication

The master MCU needs a command frame, composed of 8 data bytes, to write a 32-bit data to the registers of more than one V9261F in the broadcast communication. When receiving a command frame, V9261F should not transmit a respond frame to reply to the master MCU to avoid the communication error. On receiving a data frame, the lsb is shifted in or out firstly.

**Table 7-6 Structure of Data Byte (B7:B0) From Master MCU to V9261F on Broadcast Operation**

Order	Byte	B7	B6	B5	B4	B3	B2	B1	B0
1	Head Byte	1	1	1	1	1	1	1	0
2	Control Byte	The higher 4 bits of the target register address				0	0	0	0
3	Address Byte	The lower 8 bits of the target register address							
4	Data Byte 0	"Bit [7:0]" of the target data							
5	Data Byte 1	"Bit[15:8]" of the target data							
6	Data Byte 2	"Bit[23:16]" of the target data							
7	Data Byte 3	"Bit[31:24]" of the target data							
8	Check Byte	The checksum. Add the above 7 data bytes, invert the sum, and then add it to "0x33" to obtain the checksum.							

## 8. Interrupt

In V9261F, 7 events can trigger interrupt signals that will set the interrupt flag bits to 1s.

- **System control register self-checking interrupt:** Interrupt output cannot be masked.
- **Configuration verification interrupt:** Interrupt output cannot be masked.
- **Zero-crossing interrupt:** The voltage sign bit is output as the zero-crossing interrupt; interrupt output can be masked.
- **Current detection interrupt:** Interrupt output cannot be masked in the Current Detection Mode, and can be masked in other operation modes.
- **Power down interrupt:** Interrupt output can be masked. Please refer to “Power Supply Monitoring Circuit” for more detailed information.
- **External crystal failure interrupt:** Interrupt output can be masked. Please refer to “Crystal Oscillation Circuit” for more detailed information.
- **REF capacitor damage alarm interrupt:** Interrupt output can be masked.

The interrupt management circuit keeps on working until it is powered off.

### 8.1. System Control Register Self-Checking Interrupt

In V9261F, “bit[8:0]” of the register “SysCtrl” (0x0180) are used for key configuration for the system operation mode, and “bit[24:16]” are designed as the backup of these bits. Invert the values of “bit[8:0]”, and write them into “bit[24:16]” sequentially. The internal self-checking circuit compares the content of these bits all the time. If they are opposite to each other sequentially, it indicates the configurations are right; otherwise, an interrupt signal will be triggered, the flag bit “SYSERR” (“bit20” of “SysCtrl”, 0x0180) is set to ‘1’. The flag bit holds the state until the self-checking is corrected.

This interrupt output cannot be masked.

### 8.2. Configuration Verification Interrupt

To ensure the important configuration of control, configuration and calibration registers are in their desired states, V9261F introduces the configuration verification measure: Add the content of the register “CKSUM” (0x0133) and that of the other 24 registers listed in Table 8-1. If the sum is “0xFFFFFFFF”, it indicates all the configurations are right; otherwise, it indicates some change has occurred to the registers, an interrupt signal will be triggered, and the flag bit “CHKERR” (bit19 of SysCtrl, 0x0180) will be set to ‘1’. This interrupt output cannot be masked. The configuration verification is executed all the time, and the sum is calculated once every 5 ms. The flag bit will hold its state until the sum of the content of 25 registers is “0xFFFFFFFF”.

The register “CKSUM” should be written of the difference between “0xFFFFFFFF” and the sum of the content of the other 24 registers.

**Table 8-1 Registers for Configuration Verification**

No.	Address	Register		R/W	Default Value
1	0x0123	ZZDCI	To preset the bias for direct current	R/W	0
2	0x0124	ZZDCU	To preset the bias for direct voltage	R/W	0
3	0x0125	BPPARA	To set coefficient of the bandpass filter	R/W	0
4	0x0126	WBRTI	To set gain calibration of the fundamental current RMS	R/W	0
5	0x0127	WBPT	To set gain calibration of the fundamental active power	R/W	0
6	0x0128	WWBPT	To set offset calibration of the fundamental active power	R/W	0
7	0x0129	WBQT	To set gain calibration of the fundamental reactive power	R/W	0
8	0x012A	WWBQT	To set offset calibration of the fundamental reactive power	R/W	0
9	0x012B	WBRTU	To set gain calibration of the fundamental voltage RMS	R/W	0
10	0x012C	WARTI	To set gain calibration of the total current RMS	R/W	0
11	0x012D	WARTM	To set a value to gain calibrate the RMS value of various signal in Measurement Channel	R/W	0
12	0x012E	WAPT	To set gain calibration of the total active power	R/W	0
13	0x012F	WWAPT	To set offset calibration of the total active power	R/W	0
14	0x0130	WAQT	To set gain calibration of the total reactive power	R/W	0
15	0x0131	WWAQT	To set offset calibration of the total reactive power	R/W	0
16	0x0132	WARTU	To set gain calibration of the total voltage RMS	R/W	0
17	0x0134	IDETTH	To set the threshold for current detection	R/W	0
18	0x0181	EGYTH	To set a threshold for energy-to-pulse conversion	R/W	0
19	0x0182	CTH	To set a threshold for no-load detection	R/W	0
20	0x0183	MTPARA0	Metering control register 0	R/W	0
21	0x0184	MTPARA1	Metering control register 1	R/W	0x400000
22	0x0185	ANCtrl0	Analog Control Register 0	R/W	0x20000000
23	0x0186	ANCtrl1	Analog Control Register 1	R/W	0
24	0x0187	ANCtrl2	Analog Control Register 2	R/W	0
25	0x0133	CKSUM	Checksum register	R/W	0

## 8.3. Zero-Crossing Interrupt

V9261F supports the voltage zero-crossing interrupt.

When the voltage signal crosses the zero point, a zero-crossing interrupt will be triggered, the sign bit "USIGN" ("bit17" of "SysCtrl") will toggle following the voltage signal.

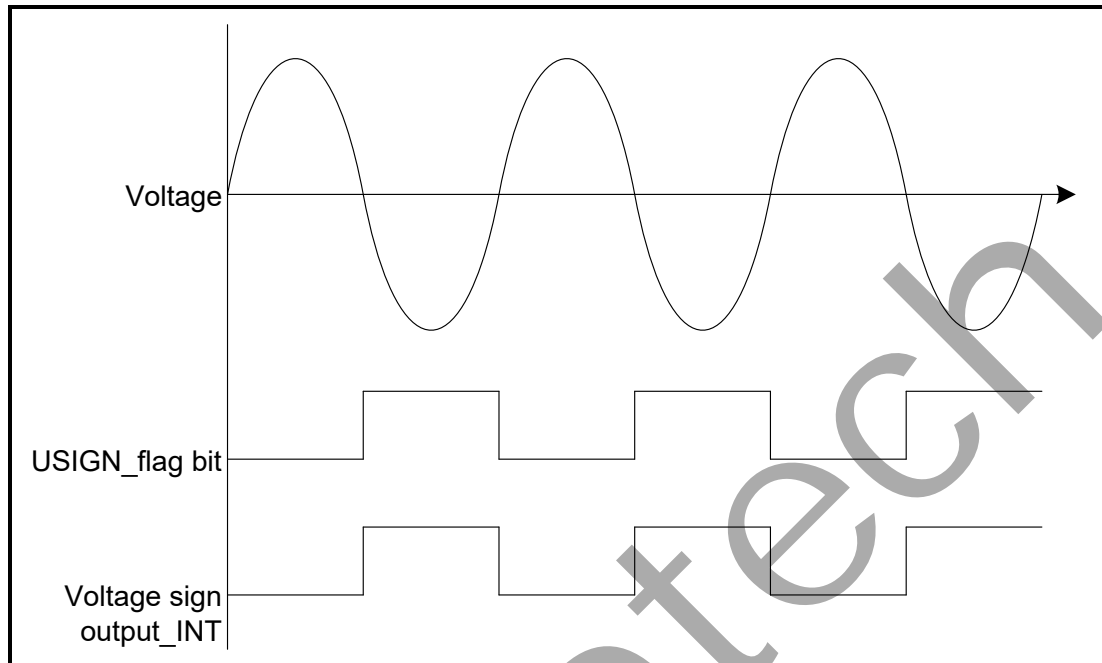

Figure 8-1 Zero-Crossing Interrupt

## 8.4. Current Detection Interrupt

V9261F integrates a current detection circuit, and supports the current detection interrupt.

Set the bit "IDETEN" ("bit12" of "MTPARA0", 0x0183) to '1' to enable the current detection. The detection circuit will compare the preset threshold for the current detection ("IDETTH", 0x0134, R/W) with the absolute value of the current signal, from which the DC component introduced by the external components and internal ADCs has been removed. Equation 8-1 depicts the signal processing:

$$I = \frac{PGA_i \times [A_i \times \sin(\omega t + \varphi) + DC_i]}{1.188} - BIAS_i \quad \text{Equation 8-1}$$

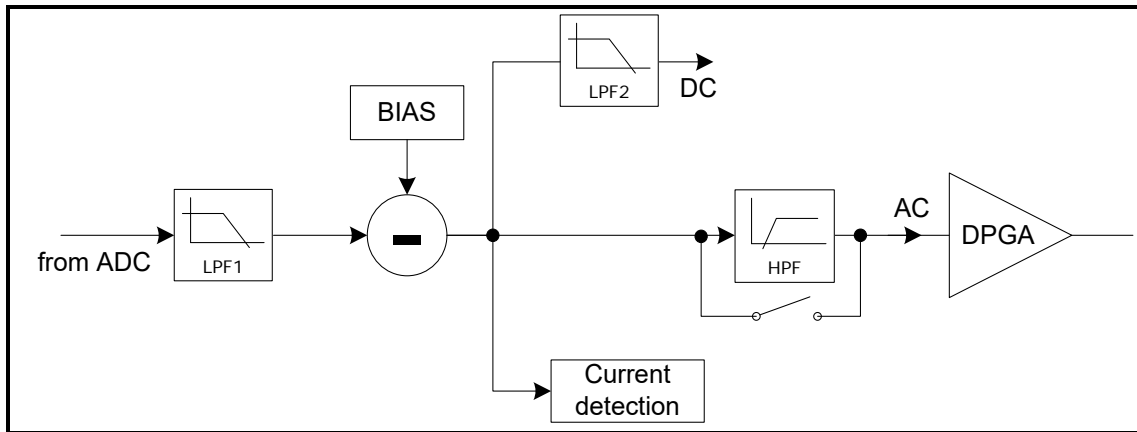

Figure 8-2 Signal Processing for Current Detection

Configure the window width for the current detection via the bit "IDETLEN" ("bit[11:8]", "MTPARA0", 0x0183). For instance, if the window width is set to '4', it means only when four continuous samples of the current signal are higher than the threshold can the current signal be strong enough for measurement and can a current detection interrupt signal be triggered. The interrupt signal will set the flag bit "DETCST" ("bit18", "SysCtrl") to '1', which can be cleared by writing '0' when the absolute value of the current signal is lower than the threshold. In the Current Detection Mode, this interrupt output cannot be masked.

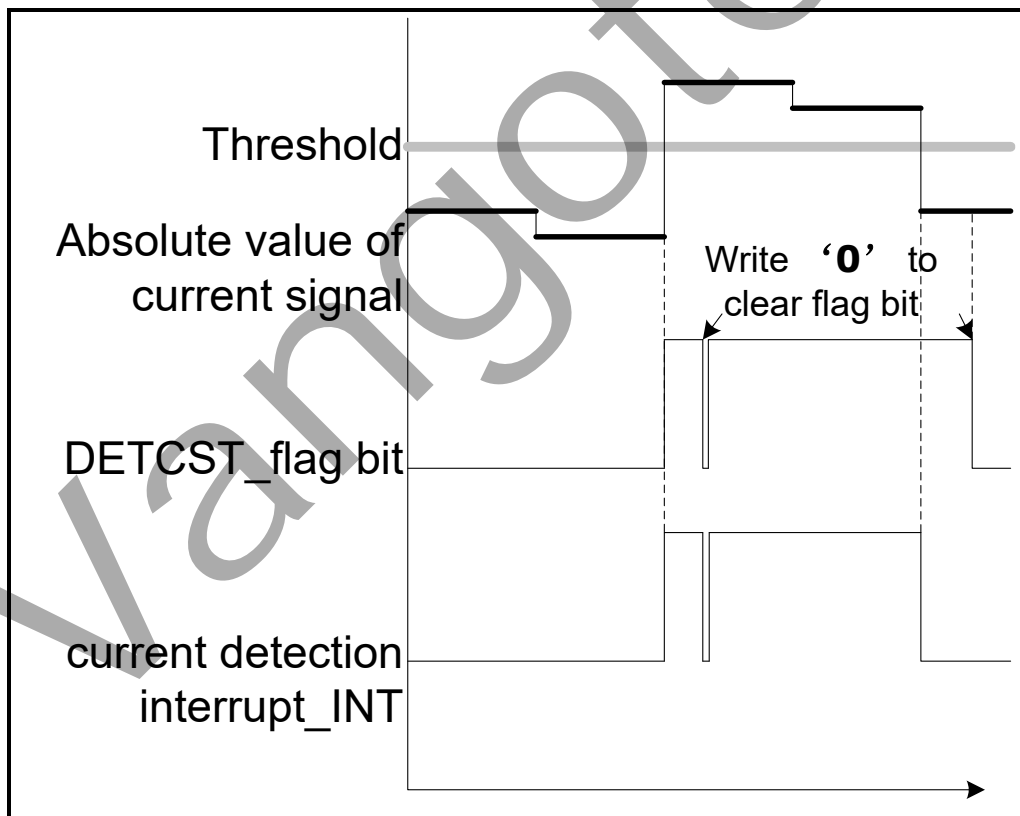

Figure 8-3 Current Detection Interrupt

## 8.5. Registers

Table 8-2 Interrupt Flag Bits

Register	Bit	R/W	Description
0x0180 SysCtrl	Bit28 PDN	R	Power-down interrupt flag bit  When the input voltage on the pin " <b>AVCC</b> " is lower than 2.8 V, this bit will be set to ' <b>1</b> '. When the input is higher than 2.8 V, this bit will be cleared.
	Bit27 HSEFAIL	R	External crystal failure interrupt flag bit  When the external crystal stops running, this bit will be set and hold the state till the crystal starts to oscillate again.  When the crystal stops running, the UART serial interface will be sourced by the 3.2-MHz RC clock (" <b>CLK2</b> ") that is not accurate enough for the UART communication, so the master MCU cannot read the value of this bit to detect the state of the crystal.
	Bit23 Reserved	R/W	The reading remains '0'.  Invert the value of " <b>bit7</b> " of " <b>SysCtrl</b> " and write it to " <b>bit23</b> " for the system control register self-checking.
	Bit22 PDN_R	R/W	The latch of "PDN". When the reset occurs, it will be '0'. After the reset, the value will be determined by the working environment.  If "PDN" is high, "PDN_R" will be put to high.  If "PDN" is low, "PDN_R" will remain the same.  If performing the write operation to "0x180", no matter what data is written into, "PDN_R" will be put to low.  Invert the value of " <b>bit6</b> " of " <b>SysCtrl</b> " and write it to " <b>bit22</b> " for the system control register self-checking.
	Bit21 REF	R/W	When the leakage occurs in the external capacitor of "REF", this bit will be set to high. Otherwise, this bit will be set to low. The level of this bit will not be changed by the read/write operation.  The default value is relevant to the working environment.  Invert the value of " <b>bit5</b> " of " <b>SysCtrl</b> " and write it to " <b>bit21</b> " for the system control register self-checking.
	Bit20 SYSERR	R/W	Read this flag bit for the state of the system control register self-checking. By default it is read out as ' <b>1</b> '. If the values of " <b>bit[8:0]</b> " and " <b>bit[24:16]</b> " are opposite to each other bit by bit, the system control register self-checking will pass, and this bit will be read out as ' <b>0</b> '; otherwise, the self-checking will fail, and this bit will be read out as ' <b>1</b> '. Only writing the exact opposite values of " <b>bit[8:0]</b> " to " <b>bit[24:16]</b> " can clear this bit.  Invert the value of " <b>bit4</b> " of " <b>SysCtrl</b> " and write it to " <b>bit20</b> " for the system control register self-checking.
Bit19	R/W	Read this bit for the state of configuration verification	

Register	Bit	R/W	Description
	CHKERR		<p>Add the content of the registers for calibration, metering control registers and analog control registers to the content of the checksum register to ensure that all the important configurations are in their desired states. If the sum is "0xFFFFFFFF", the verification will pass, and this bit will be read out as '0'; otherwise, the verification will fail, and this bit will be read out as '1'.</p> <p>Invert the value of "bit3" of "SysCtrl" and write it to "bit19" for the system control register self-checking.</p>
	Bit18 DETCST	R/W	<p>Current detection interrupt flag bit</p> <p>When some continuous samples of the current signal are higher than the preset threshold, this bit will be set to '1' to indicate that a current signal is caught. This bit can be cleared only by writing '0' to it when the current samples are lower than the threshold.</p> <p>Invert the value of "bit2" of "SysCtrl" and write it to "bit18" for the system control register self-checking.</p>
	Bit17 USIGN	R/W	<p>Voltage sign bit</p> <p>1: Negative</p> <p>0: Positive</p> <p>Read this bit to detect the sign of the voltage. This bit toggles following the sign of the voltage.</p> <p>Invert the value of "bit1" of "SysCtrl" and write it to "bit17" for the system control register self-checking.</p>

## 9. Registers

### 9.1. Analog Control Registers

All analog control registers of V9261F, located at addresses "0x0185" ~ "0x0187", will be reset to their default values when a Power-On Reset (POR), RX reset, or global software reset occurs. All the default values in the following tables are in the format of hexadecimal. All analog control registers are readable and writable. Their configurations must be verified all the time.

**Table 9-1 Analog Control Register 0 (ANCtrl0, 0x0185)**

0x0185, R/W, Analog Control Register 0, ANCtrl0			
Bit		Default	Function Description
Bit[31:30]	Reserved	0	These bits must be set to "0b11" for proper operation.
Bit29	PDRCLK	N/A	<p>Clear this bit to enable the 3.2-MHz RC Clock. It is mandatory to enable the Bandgap circuit and biasing circuit firstly. The value of the bit is uncertain when the system is reset.</p> <p>In the Sleep Mode, this bit is set to '1' automatically. In the Current Detection Mode, this bit is cleared automatically.</p> <p>In the Metering Mode, when the chip operates with full functions, it is recommended to disable this circuit (Set the bit to '1').</p>
Bit28	BIASPDN	0	<p>Set this bit to '1' to enable the biasing circuit to provide the global biasing current for ADCs and the 3.2-MHz RC oscillator. Therefore, in the Metering Mode, when the chip operates with full functions, this bit must be set to '1' before enabling ADCs and the 3.2-MHz RC oscillator. By default the biasing circuit is disabled.</p> <p>In the Sleep Mode, this bit is cleared automatically. In the Current Detection Mode, this bit is set to '1' automatically.</p>
Bit27	BGPPDN	0	<p>Set this bit to '1' to enable the Bandgap circuit to provide ADCs and the 3.2-MHz RC oscillator with the reference voltage and biasing voltage. Therefore, in the Metering Mode, when the chip operates with full functions, this bit must be set to '1' before enabling ADCs and the 3.2-MHz RC oscillator. By default the Bandgap circuit is disabled.</p> <p>In the Sleep Mode, this bit is cleared automatically. In the Current Detection Mode, this bit is set to '1' automatically.</p>
Bit26	ADCUPDN	0	<p>Set this bit to '1' to enable Voltage Channel ADC. The Bandgap circuit must be enabled before this ADC.</p> <p>Both in the Sleep Mode and the Current Detection Mode, this</p>

## 0x0185, R/W, Analog Control Register 0, ANCtrl0

Bit		Default	Function Description
			bit is cleared automatically.
Bit25	ADCMPPDN	0	<p>Set this bit to '1' to enable Measurement Channel ADC. The Bandgap circuit must be enabled before this ADC.</p> <p>Both in the Sleep Mode and the Current Detection Mode, this bit is cleared automatically.</p>
Bit24	ADCIPDN	0	<p>Set this bit to '1' to enable Current Channel ADC. The Bandgap circuit must be enabled before this ADC.</p> <p>In the Sleep Mode, this bit is cleared automatically. In the Current Detection Mode, this bit is set to '1' automatically.</p>
Bit[23:22]	Reserved	0	These bits must hold their default values for proper operation.
Bit21	XRSTEN	0	<p>Set this bit to '1' to enable the function of stimulating the external crystal when it stops running. One stimulating signal with 1-ms pulse width will be generated every 1 second under this condition. By default this function is disabled.</p> <p>In the Metering Mode, when the chip operates with full functions, it is recommended to enable this function for the best performance.</p>
Bit20	XTALPD	0	<p>Set this bit to '1' to disable the crystal oscillation circuit. By default this circuit is enabled.</p> <p>Both in the Sleep Mode and the Current Detection Mode, this bit is set to '1' automatically.</p>
Bit19	XTAL3P2M	0	<p>When a 3.2768-MHz external crystal is used, this bit must be set to '1' to disable the 1/2 divider in the crystal oscillation circuit.</p> <p>When a 6.5536-MHz crystal is used, this bit must be cleared to enable the 1/2 divider.</p>
Bit18	XTALLP	0	<p>When a 3.2768-MHz crystal is used, it is mandatory to set this bit to '1' to lower the power dissipation of the crystal oscillation circuit to a half.</p> <p>When a 6.5536-MHz crystal is used, this bit must hold its default value.</p>
Bit[17:16]	ADCLKSEL<1:0>	0	<p>To select the sampling frequency of the oversampling ADC (ADC clock, "ADCCLK"). The sampling frequency of ADCs must be a quarter or one eighth of the metering clock ("MEACLK") frequency when the chip operates with full functions in the Metering Mode.</p> <p>00: 819.2 kHz</p>

0x0185, R/W, Analog Control Register 0, ANCtrl0			
Bit		Default	Function Description
			01: 409.6 kHz 10: 204.8 kHz 11: 102.4 kHz  In the Current Detection Mode, these bits must be set to <b>"0b10"</b> to lower the power dissipation.  When the chip operates with full functions in the Metering Mode, their default values are recommended to be used for the best performance.
Bit15	Reserved	0	This bit must hold its default value for proper operation.
Bit[14:12]	REST<2:0>	0	To finely adjust the temperature coefficient of the Bandgap circuit. In order to obtain the best metering performance and temperature performance during normal metering, it must be configured according to the calculated result. The calculation method, please refer to Bandgap Circuit chapter.  000: No adjustment 001: +10 ppm 010: +20 ppm 011: +30 ppm 100: -40 ppm 101: -30 ppm 110: -20 ppm 111: -10 ppm
Bit[11:10]	IT<1:0>	0	To adjust the global bias current  00: No adjustment 01: by -33% 10: by -66% 11: by -75%  In the Current Detection Mode, it is recommended to set these bits to <b>"0b10"</b> and lower the <b>"ADCCLK"</b> frequency to 204.8 kHz to accelerate the detection.  When the chip operates with full functions in the Metering Mode, it is recommended to set these bits to <b>"0b01"</b> for the best performance.
Bit[9:8]	RESTL<1:0>	0	To roughly adjust the temperature coefficient of the Bandgap

0x0185, R/W, Analog Control Register 0, ANCtrl0			
Bit		Default	Function Description
			<p>circuit. In order to obtain the best metering performance and temperature performance during normal metering, it must be configured according to the calculated result. The calculation method, please refer to Bandgap Circuit chapter.</p> <p>00: No adjustment                      01: +70 ppm                      10: -140 ppm                      11: -70 ppm</p>
Bit7	GU	0	<p>To set analog PGA gain of analog input of Voltage Channel ADC</p> <p>0: ×4 (Recommended)                      1: ×1</p>
Bit6	Reserved	0	This bit must be set to '1' for proper operation.
Bit[5:4]	GM<1:0>	0	<p>To set analog PGA gain of analog input of Measurement Channel ADC</p> <p>The analog PGA gain is determined by the output signal of the sensor. The product of the output signal and PGA gain (Both analog and digital) must be no more than the voltage reference.</p> <p>00: ×4                      01: ×1                      10: ×32                      11: ×16</p>
Bit[3:2]	Reserved.	0	These bits must hold their default values for proper operation.
Bit[1:0]	GI<1:0>	0	<p>To set analog PGA gain of analog input of Current Channel ADC</p> <p>The analog PGA gain is determined by the output signal of the sensor. The product of the output signal and PGA gain (Both analog and digital) must be no more than the voltage reference.</p> <p>00: ×32                      01: ×16                      10: ×4                      11: ×1</p>

Table 9-2 Analog Control Register 1 (ANCtrl1, 0x0186)

0x0186, R/W, Analog Control Register 1, ANCtrl1			
Bit		Default	Function Description
Bit[31:30]	Reserved	0	These bits must hold their default values for proper operation.
Bit[29:28]	CSEL<1:0>	0	Adjust the miller capacitor in I channel ADC 00: No adjustment 01: +33% 10: +66% 11: +100%  In the Metering Mode, when the chip operates with full functions, it is recommended to set as "0b11" to get better performance and temperature coefficient.
Bit[27:23]	Reserved	0	These bits must hold their default values for proper operation.
Bit[22:20]	MEAS<2:0>	0	To select the analog input for signal processing in Measurement Channel ADC 000: Current input on pins "IBP"/"IBN" 001/010/011: Reserved 100: Temperature 101/110/111: Ground  The setting of "bit[22:20]" must match the "MEAS" (Bit[7:5]) setting in "SysCtrl" (0x0180).
Bit[19:0]	Reserved	0	These bits must hold their default values for proper operation.

Table 9-3 Analog Control Register 2 (ANCtrl2, 0x0187)

0x0187, R/W, Analog Control Register 2, ANCtrl2			
Bit		Default	Function Description
Bit[31:30]	Reserved	0	These bits must hold their default values for proper operation.
Bit[29:24]	RCTRIM<5:0>	0	To adjust the 3.2-MHz RC clock cycle  The resolution is 1% per LSB. When these bits are in their default state, no adjustment is applied.  From "0b000000" to "0b100000", the RC clock cycle is decreased by 1% per LSB; from "0b100001" ~ "0b111111", the RC clock cycle is increased by 1% per LSB.  When the chip operates with full functions in the Metering Mode, it is recommended to hold their default values for the best performance.

0x0187, R/W, Analog Control Register 2, ANCtrl2			
Bit		Default	Function Description
Bit[23:20]	Reserved	0	These bits must hold their default values for proper operation.
Bit19	XRSEL<1>	0	To adjust the negative resistance of the crystal oscillator It is not recommended to set this bit to '1' that will lead to additional 18- $\mu$ A load current.
Bit18	-	0	These bits must hold the default value for proper operation.
Bit[17:16]	XCSEL<1:0>	0	To adjust the load capacitance of the crystal oscillator By default the load capacitance is 12 pF. 00: No adjustment 01: +2 pF 10: +4 pF 11: +6 pF
Bit15	Reserved	0	This bit must hold its default value for proper operation.
Bit[14:12]	LDOVSEL<2:0>	0	To adjust the DVCCLDO output voltage 000: No adjustment 001: -0.1 V 010: +0.2 V 011: +0.1 V 100: -0.4 V 101: -0.5 V 110: -0.2 V 111: -0.3 V
Bit11	Reserved	0	This bit must hold its default value for proper operation.
Bit10	SHORTU	0	When a DC voltage signal is applied to Voltage Channel, it is recommended to set this bit to '1' to short the amplifier in the voltage channel to obtain the bias voltage of ADC itself. By default this function is disabled.
Bit9	Reserved	0	This bit must hold its default value for proper operation.
Bit8	SHORTI	0	When a DC current signal is applied to Current Channel, it is recommended to set this bit to '1' to short the amplifier in the current channel to obtain the bias current of ADC itself. By default this function is disabled.
Bit[7:0]	Reserved	0	These bits must hold their default values for proper operation.

## 9.2. System Control Register

When a Power-On Reset (POR), RX reset, or global software reset occurs, the system control register will be reset to its default state. If not specifically noted, the default values in the tables of this section are in the format of hexadecimal.

In V9261F, "bit[8:0]" of register "SysCtrl" (0x0180) are used for key configuration for the operation mode, and "bit[24:16]" are designed as the backup of their configurations. Invert the values of "bit[8:0]", and write them into "bit[24:16]" sequentially. The internal self-checking circuit compares the content of both parts all the time. If they are opposite to each other bit by bit, it indicates the configurations are right; otherwise, an interrupt signal will be triggered, and the flag bit "SYSERR" (bit20 of SysCtrl) will be set to '1'.

**Table 9-4 System Control Register (0x0180, SysCtrl)**

0x0180, System Control Register, SysCtrl				
Bit		R/W	Default	Function Description
Bit31	CFCRP	R	0	Flag for Staring/Creeping State indication 0: Creeping State 1: Start metering
Bit30	Reserved	R	N/A	It is meaningless to read of this bit.
Bit29	BISTERR	R	0	The internal RAM will be self-checked immediately after a global reset event occurs. The self-checking will be finished in 1.25 ms. After the self-checking, if this bit is read out as '1', it indicates that the self-checking of the internal RAM fails. If this bit is read out as '0', it indicates that the internal RAM is ready to be accessed; but if this bit is read out as '1' again after another reset event, it indicates that there is something wrong with RAM.
Bit28	PDN	R	0	Power-down interrupt flag bit When the input voltage on the pin "AVCC" is lower than $2.8 \pm 0.14$ V, this bit will be set to '1'. When the power down event is disappeared, this bit will be cleared.
Bit27	HSEFAIL	R	0	External crystal failure interrupt flag bit When the external crystal stops running, this bit will be set and hold the state till the crystal starts to oscillate again. When the crystal stops running, the UART serial interface is sourced by the 3.2-MHz RC clock ("CLK2") that is not accurate enough for the UART communication, so the master MCU cannot read the value of this bit to detect the state of the crystal.

0x0180, System Control Register, SysCtrl																												
Bit		R/W	Default	Function Description																								
Bit[26:25]	RSTSRC	R	0	Flag bits to indicate the reset source <table border="1"> <thead> <tr> <th>Bit26</th> <th>Bit25</th> <th>Bit24</th> <th>Description</th> </tr> </thead> <tbody> <tr> <td>0</td> <td>0</td> <td>1</td> <td>A POR event occurred.</td> </tr> <tr> <td>0</td> <td>0</td> <td>0</td> <td>Reserved.</td> </tr> <tr> <td>0</td> <td>1</td> <td>1</td> <td>An RX reset event occurred.</td> </tr> <tr> <td>0</td> <td>1</td> <td>0</td> <td>Reserved</td> </tr> <tr> <td>1</td> <td>0</td> <td>0</td> <td>A global software reset occurred.</td> </tr> </tbody> </table>	Bit26	Bit25	Bit24	Description	0	0	1	A POR event occurred.	0	0	0	Reserved.	0	1	1	An RX reset event occurred.	0	1	0	Reserved	1	0	0	A global software reset occurred.
Bit26		Bit25		Bit24	Description																							
0	0	1	A POR event occurred.																									
0	0	0	Reserved.																									
0	1	1	An RX reset event occurred.																									
0	1	0	Reserved																									
1	0	0	A global software reset occurred.																									
Bit24	R/W		Read of <b>"bit24"</b> together with <b>"bit[26:24]"</b> to detect the reset source.  Invert the value of <b>"bit8"</b> of <b>"SysCtrl"</b> and write it to <b>"bit24"</b> for the system control register self-checking.																									
bit23	Reserved	R/W	0	The reading remains '0'.  Invert the value of <b>"bit7"</b> of <b>"SysCtrl"</b> and write it to <b>"bit23"</b> for the system control register self-checking.																								
bit22	PDN_R	R/W	N/A	The latch of "PDN". When the reset occurs, it will be '0'. After the reset, the value will be determined by the working environment.  If "PDN" is high, "PDN_R" will be put to high.  If "PDN" is low, "PDN_R" will remain the same.  If performing the write operation to "0x180", no matter what data is written into, "PDN_R" will be put to low.  Invert the value of <b>"bit6"</b> of <b>"SysCtrl"</b> and write it to <b>"bit22"</b> for the system control register self-checking.																								
bit21	REF	R/W	N/A	When the leakage occurs in the external capacitor of "REF", this bit will be set to high. Otherwise, this bit will be set to low. The level of this bit will not be changed by the read/write operation.  The default value is relevant to the working environment.  Invert the value of <b>"bit5"</b> of <b>"SysCtrl"</b> and write it to <b>"bit21"</b> for the system control register self-checking.																								
Bit20	SYSERR	R/W	1	Read this flag bit for the state of the system control register self-checking. By default it is read out as '1'. If the values of <b>"bit[8:0]"</b> and <b>"bit[24:16]"</b> are opposite to each other bit by bit, the system control register self-checking will pass, and this bit will be read out as '0'; otherwise, the self-checking will fail, and this bit will be read out as '1'. Only writing the exact																								

0x0180, System Control Register, SysCtrl				
Bit		R/W	Default	Function Description
				<p>opposite values of "bit[8:0]" to "bit[24:16]" can clear this bit.</p> <p>Invert the value of "bit4" of "SysCtrl" and write it to "bit20" for the system control register self-checking.</p>
Bit19	CHKERR	R/W	0	<p>Read this bit for the state of configuration verification.</p> <p>Add the content of the registers for calibration, metering control registers and analog control registers to the content of the checksum register to ensure that all the important configurations are in their desired states. If the sum is "0xFFFFFFFF", the verification will pass, and this bit will be read out as '0'; otherwise, the verification will fail, and this bit will be read out as '1'.</p> <p>Invert the value of "bit3" of "SysCtrl" and write it to "bit19" for the system control register self-checking.</p>
Bit18	DETCST	R/W	0	<p>Current detection interrupt flag bit</p> <p>When some continuous samples of the current signal are higher than the preset threshold, this bit will be set to '1' to indicate that a current signal is caught. This bit can be cleared only by writing '0' to it when the current samples are lower than the threshold.</p> <p>Invert the value of "bit2" of "SysCtrl" and write it to "bit18" for the system control register self-checking.</p>
Bit17	USIGN	R/W	0	<p>Voltage sign bit</p> <p>1: Negative</p> <p>0: Positive</p> <p>Read this bit to detect the sign of the voltage. This bit toggles following the sign of the voltage.</p> <p>Invert the value of "bit1" of "SysCtrl" and write it to "bit17" for the system control register self-checking.</p>
Bit16	Reserved	R/W	N/A	<p>It is meaningless to read of this bit.</p> <p>Invert the value of "bit0" of "SysCtrl" and write it to "bit16" for the system control register self-checking.</p>
Bit[15:9]	Reserved	R	N/A	<p>It is meaningless to read of this bit.</p>
Bit8	Reserved	R/W	N/A	<p>It is meaningless to read of this bit. This bit is writable, but it is meaningless to write of it.</p> <p>Invert the value of this bit and write it to "bit24" for the <b>system control register self-checking</b>.</p>

0x0180, System Control Register, SysCtrl				
Bit		R/W	Default	Function Description
Bit[7:5]	MEAS	R/W	0	To select the analog input for signal processing in Measurement Channel ADC 000: Current input on pins "IBP"/"IBN" 001/010/011: Reserved 100: Temperature 101/110/111: Ground Invert the values of these bits and write them to "bit[23:21]" for the system control register self-checking.
Bit[4:2]	Reserved	R/W	1	By default these bits are read out as "0b001". These bits are writable, but it is meaningless to write of them. Invert the values of these bits and write them to "bit[20:18]" for the system control register self-checking.
Bit1	CKMDIV	R/W	0	To select the clock frequency for the Vango metering architecture ("MEACLK") 1: 819.2 kHz 0: 3.2768 MHz Invert the value of this bit and write it to "bit17" for the system control register self-checking.
Bit0	SLEEP	R/W	0	Set this bit to '1' to disable "CLK1" and "CLK2" and force the system to enter the Sleep Mode. Invert the value of this bit and write it to "bit16" for the system control register self-checking.

### 9.3. Metering Control Registers

All metering control registers, located at addresses "0x0183" and "0x0184", will be reset to their default values when a power-on reset, RX reset, or global software reset occurs. If not specifically noted, the default values in the following tables are in the format of hexadecimal. All metering control registers are readable and writable. Their configurations must be verified all the time.

**Table 9-5 Metering Control Register 0 (0x0183, MTPARA0)**

0x0183, R/W, Metering Control Register 0, MTPARA0			
Bit		Default	Function Description
Bit31	CFEN	0	Set this bit to '1' to enable CF pulse output. By default this function is disabled.
Bit30	EGYEN	0	Set this bit to '1' to enable energy accumulation and energy-to-pulse conversion.

## 0x0183, R/W, Metering Control Register 0, MTPARA0

Bit		Default	Function Description
Bit29	CRPEN	0	Set this bit to '1' to enable no-load detection. By default this function is disabled.
Bit28	CLKSEL	0	When the "MEACLK" frequency is 3.2768 MHz, clear this bit to inform the C 3.2768 MHz. When the "MEACLK" frequency is 819.2 kHz, set this bit to '1' to work at 819.2 kHz.
Bit[27:26]	CFSEL	0	To select the energy to be converted into CF pulse 01: Positive energy 10: Negative energy 00/11: The sum of the positive and negative energy
Bit[25:24]	CFFAST	0	To accelerate the CF pulse generation rate 00: ×1 01: ×4 10: ×8 11: ×16
Bit[23:22]	ENGSEL	0	To select the power for energy accumulation 00: Instantaneous total active power 01: Instantaneous total reactive power 10: Instantaneous fundamental active power 11: Instantaneous fundamental reactive power
Bit[21:15]	Reserved	N/A	These bits must be set as '0' for proper operation.
Bit[14:13]	BPFSFT	0	To set the number of the bits of the bandpass filter to be shifted 00: 8 bits 01: 9 bits 10: 10 bits 11: 11 bits The fewer bits are shifted, the less time the filter needs to response, and the deviation is.
Bit12	IDETEN	0	To enable current detection 1: Enable 0: Disable
Bit[11:8]	IDETLEN	0	To set the width of filtering window for current detection 0000: 1; 0001: 2; 0010: 3; 0011: 4; 0100: 5; 0101: 6; 0110: 7; 0111: 8;

## 0x0183, R/W, Metering Control Register 0, MTPARA0

Bit		Default	Function Description
			1100: 13; 1101: 14; 1110: 15; 1111: 16.  For instance, if "IDETLEN" is set to "0b0011", the filtering window width is 4. If the number of continuous current samples are higher than the threshold is it defined that a current is detected.
Bit7	CF_PROT	0	0: Disable CF power-down protection  1: Enable CF power-down protection
Bit[6:0]	Reserved	0	These bits must hold their default values for proper operation.

**Table 9-6 Metering Control Register 1 (0x0184, MTPARA1)**

0x0184, R/W, Metering Control Register 1, MTPARA1			
Bit		Default	Function Description
Bit[31:28]	PGAM	0	To set digital PGA gain for various signal input of Measurement Channel 0000: ×1; 0001: ×1/2; 0010: ×1/4; 0011: ×1/8; 0100: ×1/16; 0101: ×1/32;  1000: ×1; 1001: ×2; 1010: ×4; 1011: ×8; 1100: ×16; 1101: ×32.
Bit27	ONM	0	To enable digital signal input of Measurement Channel for digital signal processing  1: Enable  0: Disable. When this bit is cleared, a constant '0' is input for the digital signal processing.
Bit26	SELI	0	To select current channels for digital signal processing when pins "IBP" and "IBN" are used  1: Current IA is sent to Measurement Channel for processing; current IB is sent to Current Channel for processing.  0: Current IA is sent to Current Channel for processing; Current IB is sent to Measurement Channel for processing.
Bit25	CIB	0	Set this bit to '1' to enable digital signal processing in Measurement Channel. By default this function is disabled.
Bit[24:23]	Reserved	0	These bits must be set to their default values for proper operation.
Bit22	CKSUM	1	When this bit is set to '1', only configuration verification is activated. When this bit is cleared, all functions of the Vango metering architecture are activated.  In the Current Detection Mode, this bit is cleared automatically.
Bit21	IDET	0	When the bit "CKSUM" (bit22) is cleared, set this to '1' to activate the configuration verification and current detection only; clear this bit to execute all computations.

<b>0x0184, R/W, Metering Control Register 1, MTPARA1</b>			
<b>Bit</b>		<b>Default</b>	<b>Function Description</b>
			<p>In the Current Detection Mode, this bit is set to '1' automatically.</p> <p>When "CKSUM" is set to '0' and "IDET" is set to '1', users can preset a value in the register "DATACP" (0x0189) for energy accumulation. When both "CKSUM" and "IDET" are cleared, users can select an average power to transfer it to register "DATACP" for the energy accumulation.</p>
Bit20	BPHPF	0	<p>By default the high pass filter is enabled to remove DC component from the signals and only the AC component of the signals are sent for RMS and power calculation.</p> <p>When this bit is set to '1', the high pass filter is disabled.</p>
Bit19	ENPHC	0	Set this bit to '1' to enable phase compensation. By default this function is disabled.
Bit18	PHCIU	0	Set this bit to '1' to delay voltage for phase compensation. Clear this bit to delay current for phase compensation.
Bit17	ONI	0	<p>To enable digital signal input of current channel for digital signal processing</p> <p>1: Enable</p> <p>0: Disable. When this bit is cleared, a constant '0' is input for the digital signal processing.</p>
Bit16	ONU	0	<p>To enable digital signal input of voltage channel for digital signal processing</p> <p>1: Enable</p> <p>0: Disable. When this bit is cleared, a constant '0' is input for the digital signal processing.</p>
Bit[15:8]	PHC	0	To set the absolute value for phase compensation. The resolution is 0.0055°/lsb, and a phase error up to 1.4° can be calibrated.
Bit[7:4]	PGAI	0	<p>To set digital PGA gain of current input</p> <p>0000: ×1; 0001: ×1/2; 0010: ×1/4; 0011: ×1/8; 0100: ×1/16; 0101: ×1/32;</p> <p>1000: ×1; 1001: ×2; 1010: ×4; 1011: ×8; 1100: ×16; 1101: ×32.</p>
Bit[3:0]	PGAU	0	<p>To set digital PGA gain of voltage input</p> <p>0000: ×1; 0001: ×1/2; 0010: ×1/4; 0011: ×1/8; 0100: ×1/16; 0101: ×1/32;</p> <p>1000: ×1; 1001: ×2; 1010: ×4; 1011: ×8; 1100: ×16; 1101: ×32.</p>

## 9.4. Data Registers

When a Power-On Reset (POR), RX reset, or global software reset occurs, all data registers are reset to their default states. If not specifically noted, all the default values in the following tables are in the format of hexadecimal.

**Table 9-7 Registers for DC Component (R/W)**

Register		R/W	Format	Description
0x0114	DCU	R/W	32-bit, 2'-complement	The DC component of voltage signal  When the <b>"MEACLK"</b> frequency is 3.2768 MHz, this register will be updated in 160 ms, and settled in 300 ms.  When the <b>"MEACLK"</b> frequency is 819.2 kHz, this register will be updated in 640 ms and settled in 1200 ms.
0x0115	DCI	R/W	32-bit, 2'-complement	The DC component of current signal  When the <b>"MEACLK"</b> frequency is 3.2768 MHz, this register will be updated in 160 ms, and settled in 300 ms.  When the <b>"MEACLK"</b> frequency is 819.2 kHz, this register will be updated in 640 ms and settled in 1200 ms.  When Current Channel is used to process the current signal input from the pins <b>"IAP"/ "IAN"</b> (IA), this register will be used to store the DC component of IA. When Current Channel is used to process the current signal input from the pins <b>"IBP"/"IBN"</b> (IB), this register will be used to store the DC component of IB.
0x0116	DCM	R/W	32-bit, 2'-complement	The DC component of various signals processed in Measurement Channel  When the <b>"MEACLK"</b> frequency is 3.2768 MHz, this register will be updated in 160 ms, and settled in 300 ms.  When the <b>"MEACLK"</b> frequency is 819.2 kHz, this register will be updated in 640 ms and settled in 1200 ms.
0x00F9	DCIM	R/W	32-bit, 2'-complement	When Measurement Channel (M) is used to process the current signal input from pins <b>"IBP"/"IBN"</b> or <b>"IAP"/"IAN"</b> , this register will be the backup of content of register <b>"DCM"</b> (0x0116), and the master MCU should read this register for the measurement.
0x0101	DCTM	R/W	32-bit, 2'-complement	When Measurement Channel (M) is used to measure temperature, this register will be the backup of the content of register <b>"DCM"</b> (0x0116), and the master MCU should read this register for the measurement.

**Table 9-8 Registers for Line Frequency (R)**

Register		R/W	Format	Description
0x019A	FREQ	R	32-bit, 2'-complement	<p>The instantaneous line frequency</p> <p>When the <b>"MEACLK"</b> frequency is 3.2768 MHz, this register will be updated in 20 ms; when the <b>"MEACLK"</b> frequency is 819.2 kHz, this register will be updated in 80 ms. The settling time for the register is determined by the amplitude and quality of the signal.</p>
0x011D	SAFREQ	R	32-bit, 2'-complement	<p>The line frequency per second</p> <p>When the <b>"MEACLK"</b> frequency is 3.2768 MHz, this register will be updated in 1.28 s; when the <b>"MEACLK"</b> frequency is 819.2 kHz, this register will be updated in 5.12 s. The settling time for the register is determined by the amplitude and quality of the signal.</p>
0x011E	AFREQ	R	32-bit, 2'-complement	<p>The average line frequency</p> <p>When the <b>"MEACLK"</b> frequency is 3.2768 MHz, this register will be updated in 10.24 s; when the <b>"MEACLK"</b> frequency is 819.2 kHz, this register will be updated in 40.96 s. The settling time for the register is determined by the amplitude and quality of the signal.</p>

**Table 9-9 Registers for RMS Values of Total/Fundamental Signals (R/W)**

Register		R/W	Format	Description
0x0105	ARRTI	R/W	32-bit, 2'-complement	<p>The raw total current RMS</p> <p>When the <b>"MEACLK"</b> frequency is 3.2768 MHz, the register will be updated in 160 ms and settled in 500 ms. When the <b>"MEACLK"</b> frequency is 819.2 kHz, the register will be updated in 640 ms and settled in 2000 ms.</p> <p>When Current Channel is used to process the current signal input from pins <b>"IAP"/"IAN"</b> (IA), this register will be used to store the raw RMS value of total IA. When Current Channel is used to process the current signal input from pins <b>"IBP"/"IBN"</b> (IB), this register will be used to store the raw RMS value of total IB.</p>
0x0104	ARRTU	R/W	32-bit, 2'-complement	<p>The raw total voltage RMS</p> <p>When the <b>"MEACLK"</b> frequency is 3.2768 MHz, the register will be updated in 160 ms and settled in 500 ms. When the <b>"MEACLK"</b> frequency is 819.2 kHz, the register will be updated in 640 ms and settled in 2000 ms.</p>

Register		R/W	Format	Description
0x0106	ARRTM	R/W	32-bit, 2'-complement	<p>The raw RMS value of the various signal of Measurement Channel</p> <p>When the <b>"MEACLK"</b> frequency is 3.2768 MHz, the register is updated in 160 ms and settled in 500 ms. When the <b>"MEACLK"</b> frequency is 819.2 kHz, the register will be updated in 640 ms and settled in 2000 ms.</p>
0x0109	BRRTU	R/W	32-bit, 2'-complement	<p>The raw fundamental voltage RMS.</p> <p>When the <b>"MEACLK"</b> frequency is 3.2768 MHz, the register will be updated in 160 ms and settled in 500 ms. When the <b>"MEACLK"</b> frequency is 819.2 kHz, the register will be updated in 640 ms and settled in 2000 ms.</p>
0x010A	BRRTI	R/W	32-bit, 2'-complement	<p>The raw fundamental current RMS</p> <p>When the <b>"MEACLK"</b> frequency is 3.2768 MHz, the register will be updated in 160 ms and settled in 500 ms. When the <b>"MEACLK"</b> frequency is 819.2 kHz, the register will be updated in 640 ms and settled in 2000 ms.</p> <p>When Current Channel is used to process the current signal input from pins <b>"IAP"/"IAN"</b> (IA), this register will be used to store the raw RMS value of fundamental IA. When Current Channel is used to process the current signal input from pins <b>"IBP"/"IBN"</b> (IB), this register will be used to store the raw RMS value of fundamental IB.</p>
0x010E	ARTI	R/W	32-bit, 2'-complement	<p>The instantaneous total current RMS</p> <p>When the <b>"MEACLK"</b> frequency is 3.2768 MHz, the register will be updated in 160 ms and settled in 500 ms. When the <b>"MEACLK"</b> frequency is 819.2 kHz, the register will be updated in 640 ms and settled in 2000 ms.</p> <p>When Current Channel is used to process the current signal input from pins <b>"IAP"/"IAN"</b> (IA), this register will be used to store the instantaneous RMS value of total IA. When Current Channel is used to process the current signal input from pins <b>"IBP"/"IBN"</b> (IB), this register is to store the instantaneous RMS value of total IB.</p>
0x010D	ARTU	R/W	32-bit, 2'-complement	<p>The instantaneous total voltage RMS</p> <p>When the <b>"MEACLK"</b> frequency is 3.2768 MHz, the register will be updated in 160 ms and settled in 500 ms. When the <b>"MEACLK"</b> frequency is 819.2 kHz, the register will be updated in 640 ms and settled in 2000 ms.</p>

Register		R/W	Format	Description
0x010F	ARTM	R/W	32-bit, 2'-complement	<p>The instantaneous RMS value of the various signal of Measurement Channel</p> <p>When the <b>"MEACLK"</b> frequency is 3.2768 MHz, the register will be updated in 160 ms and settled in 500 ms. When the <b>"MEACLK"</b> frequency is 819.2 kHz, the register will be updated in 640 ms and settled in 2000 ms.</p>
0x00F8	ARTIM	R/W	32-bit, 2'-complement	<p>When Measurement Channel (M) is used to process the current signal input from pins <b>"IBP"/"IBN"</b> or <b>"IAP"/"IAN"</b>, this register is the backup of the content of register <b>"ARTM"</b> (0x010F), and the master MCU should read this register for the measurement.</p>
0x0112	BRTU	R/W	32-bit, 2'-complement	<p>The instantaneous fundamental voltage RMS</p> <p>When the <b>"MEACLK"</b> frequency is 3.2768 MHz, the register will be updated in 160 ms and settled in 500 ms. When the <b>"MEACLK"</b> frequency is 819.2 kHz, the register will be updated in 640 ms and settled in 2000 ms.</p>
0x0113	BRTI	R/W	32-bit, 2'-complement	<p>The instantaneous fundamental current RMS</p> <p>When the <b>"MEACLK"</b> frequency is 3.2768 MHz, the register will be updated in 160 ms and settled in 500 ms. When the <b>"MEACLK"</b> frequency is 819.2 kHz, the register will be updated in 640 ms and settled in 2000 ms.</p> <p>When Current Channel is used to process the current signal input from pins <b>"IAP"/"IAN"</b> (IA), this register will be used to store the instantaneous RMS value of fundamental IA. Otherwise, this register will be used to store the instantaneous RMS value of fundamental IB.</p>
0x011B	AARTU	R/W	32-bit, 2'-complement	<p>The average total voltage RMS</p> <p>When the <b>"MEACLK"</b> frequency is 3.2768 MHz, the register will be updated in 1.28 s and settled in 3 s. When the <b>"MEACLK"</b> frequency is 819.2 kHz, the register will be updated in 5.12 s and settled in 12 s.</p>

Register		R/W	Format	Description
0x011C	AARTI	R/W	32-bit, 2'-complement	<p>The average total current RMS</p> <p>When the <b>"MEACLK"</b> frequency is 3.2768 MHz, the register will be updated in 1.28 s and settled in 3 s. When the <b>"MEACLK"</b> frequency is 819.2 kHz, the register will be updated in 5.12 s and settled in 12 s.</p> <p>When Current Channel is used to process the current signal input from pins <b>"IAP"/"IAN"</b> (IA), this register will be used to store the average RMS value of total IA. Otherwise, this register will be used to store the average RMS value of total IB.</p>
0x0117	AARTM	R/W	32-bit, 2'-complement	<p>The average RMS value of the various signal of Measurement Channel</p> <p>When the <b>"MEACLK"</b> frequency is 3.2768 MHz, the register will be updated in 1.28 s and settled in 3 s. When the <b>"MEACLK"</b> frequency is 819.2 kHz, the register will be updated in 5.12 s and settled in 12 s.</p>
0x0121	ABRTU	R/W	32-bit, 2'-complement	<p>The average fundamental voltage RMS</p> <p>When the <b>"MEACLK"</b> frequency is 3.2768 MHz, the register will be updated in 1.28 s and settled in 3 s. When the <b>"MEACLK"</b> frequency is 819.2 kHz, the register will be updated in 5.12 s and settled in 12 s.</p>
0x0122	ABRTI	R/W	32-bit, 2'-complement	<p>The average fundamental current RMS</p> <p>When the <b>"MEACLK"</b> frequency is 3.2768 MHz, the register will be updated in 1.28 s, and settled in 3 s. When the <b>"MEACLK"</b> frequency is 819.2 kHz, the register will be updated in 5.12 s and settled in 12 s.</p> <p>When Current Channel is used to process the current signal input from pins <b>"IAP"/"IAN"</b> (IA), this register is to store the average RMS value of fundamental IA. Otherwise, this register is to store the average RMS value of fundamental IB.</p>

**Table 9-10 Total/Fundamental Active/Reactive Power Registers (R/W)**

Register		R/W	Format	Description
0x0102	RAP	R/W	32-bit, 2'-complement	<p>The raw total active power</p> <p>When the <b>"MEACLK"</b> frequency is 3.2768 MHz, the register will be updated in 160 ms and settled in 500 ms. When the <b>"MEACLK"</b> frequency is 819.2 kHz, the register will be updated in 640 ms and settled in 2000 ms.</p>

Register		R/W	Format	Description
0x0103	RAQ	R/W	32-bit, 2'-complement	<p>The raw total reactive power</p> <p>When <b>"MEACLK"</b> frequency is 3.2768 MHz, the register will be updated in 160 ms and settled in 500 ms. When the <b>"MEACLK"</b> frequency is 819.2 kHz, the register will be updated in 640 ms and settled in 2000 ms.</p>
0x0107	RBP	R/W	32-bit, 2'-complement	<p>The raw fundamental active power</p> <p>When the <b>"MEACLK"</b> frequency is 3.2768 MHz, the register will be updated in 160 ms and settled in 500 ms. When the <b>"MEACLK"</b> frequency is 819.2 kHz, the register will be updated in 640 ms and settled in 2000 ms.</p>
0x0108	RBQ	R/W	32-bit, 2'-complement	<p>The raw fundamental reactive power</p> <p>When the <b>"MEACLK"</b> frequency is 3.2768 MHz, the register will be updated in 160 ms and settled in 500 ms. When the <b>"MEACLK"</b> frequency is 819.2 kHz, the register will be updated in 640 ms and settled in 2000 ms.</p>
0x010B	IAP	R/W	32-bit, 2'-complement	<p>The instantaneous total active power</p> <p>When the <b>"MEACLK"</b> frequency is 3.2768 MHz, the register will be updated in 160 ms and settled in 500 ms. When the <b>"MEACLK"</b> frequency is 819.2 kHz, the register will be updated in 640 ms and settled in 2000 ms.</p>
0x010C	IAQ	R/W	32-bit, 2'-complement	<p>The instantaneous total reactive power</p> <p>When the <b>"MEACLK"</b> frequency is 3.2768 MHz, the register will be updated in 160 ms and settled in 500 ms. When the <b>"MEACLK"</b> frequency is 819.2 kHz, the register will be updated in 640 ms and settled in 2000 ms.</p>
0x0110	IBP	R/W	32-bit, 2'-complement	<p>The instantaneous fundamental active power</p> <p>When the <b>"MEACLK"</b> frequency is 3.2768 MHz, the register will be updated in 160 ms and settled in 500 ms. When the <b>"MEACLK"</b> frequency is 819.2 kHz, the register will be updated in 640 ms and settled in 2000 ms.</p>
0x0111	IBQ	R/W	32-bit, 2'-complement	<p>The instantaneous fundamental reactive power</p> <p>When the <b>"MEACLK"</b> frequency is 3.2768 MHz, the register will be updated in 160 ms and settled in 500 ms. When the <b>"MEACLK"</b> frequency is 819.2 kHz, the register will be updated in 640 ms and settled in 2000 ms.</p>

Register		R/W	Format	Description
0x0119	AAP	R/W	32-bit, 2'-complement	The average total active power  When the <b>"MEACLK"</b> frequency is 3.2768 MHz, the register will be updated in 1.28 s and settled in 3 s. When the <b>"MEACLK"</b> frequency is 819.2 kHz, the register will be updated in 5.12 s and settled in 12 s.
0x011A	AAQ	R/W	32-bit, 2'-complement	The average total reactive power  When the <b>"MEACLK"</b> frequency is 3.2768 MHz, the register will be updated in 1.28 s and settled in 3 s. When the <b>"MEACLK"</b> frequency is 819.2 kHz, the register will be updated in 5.12 s and settled in 12 s.
0x011F	ABP	R/W	32-bit, 2'-complement	The average fundamental active power  When the <b>"MEACLK"</b> frequency is 3.2768 MHz, the register will be updated in 1.28 s and settled in 3 s. When the <b>"MEACLK"</b> frequency is 819.2 kHz, the register will be updated in 5.12 s and settled in 12 s.
0x0120	ABQ	R/W	32-bit, 2'-complement	The average fundamental reactive power  When the <b>"MEACLK"</b> frequency is 3.2768 MHz, the register will be updated in 1.28 s, and settled in 3 s. When the <b>"MEACLK"</b> frequency is 819.2 kHz, the register will be updated in 5.12 s and settled in 12 s.

**Table 9-11 Active/Reactive Energy Accumulators (R/W)**

Register		R/W	Format	Description
0x01A1	PEGY	R/W	32-bit, unsigned.	Accumulating positive power: Total/Fundamental and active/reactive power  This register is physically 46-bit, but only the most significant 32 bits are active. When the <b>"MEACLK"</b> frequency is 3.2768 MHz, the accumulation frequency will be 204.8 kHz. When the <b>"MEACLK"</b> frequency is 819.2 kHz, the accumulation frequency will be 102.4 kHz.
0x01A2	NEGY	R/W	32-bit, unsigned.	Accumulating negative power: Total/Fundamental and active/reactive power  This register is physically 46-bit, but only the most significant 32 bits are active. When the <b>"MEACLK"</b> frequency is 3.2768 MHz, the accumulation frequency will be 204.8 kHz. When the <b>"MEACLK"</b> frequency is 819.2 kHz, the accumulation frequency will be 102.4 kHz.

**Table 9-12 Active/Reactive CF Pulse Counters (R/W)**

Register	R/W	Format	Description
----------	-----	--------	-------------

Register		R/W	Format	Description
0x01A3	PCFCNT	R/W	32-bit, unsigned	Positive CF pulse counter
0x01A4	NCFCNT	R/W	32-bit, unsigned	Negative CF pulse counter

**Table 9-13 Power Register (R/W)**

Register		R/W	Format	Description
0x0189	DATA CP	R/W	32-bit, 2' complement	When bits "CKSUM" and "IDET" ("bit22" and "bit21" of "MTPARA0", 0x0183) are set to "0b01", the master MCU can write a value to this register for the energy accumulation.  When both "CKSUM" and "IDET" ("bit22" and "bit21" of "MTPARA0", 0x0183) are cleared, the master MCU can select a power and transfer it to this register for the normal energy accumulation.

## 9.5. Registers for Calibration

When a Power-On Reset (POR), RX reset, or global software reset occurs, all registers for calibration will be reset to their default states. If not specifically noted, all the default values in the following tables are in the format of hexadecimal. Their contents must be verified all the time.

**Table 9-14 Registers for Presetting Bias for Direct Current/Voltage**

Register		Default	R/W	Format	Description
0x0123	ZZDCI	0	R/W	32-bit 2'-complement	Preset a value to remove the DC bias from the current signal. The content of this register must be verified.
0x0124	ZZDCU	0	R/W	32-bit 2'-complement	Preset a value to remove the DC bias from the voltage signal. The content of this register must be verified.

**Table 9-15 Registers for Calibrating Voltage/Current RMS (R/W)**

Register		Default	R/W	Format	Description	
0x012C	WARTI	0	R/W	32-bit, 2'-complement	Set a value to gain calibrate the total current RMS.	The actual value in decimal form is acquired by dividing the register reading by 2 <sup>31</sup> .  The values of RMS before and after calibration have a relationship as follows:  RMS=RMS'×(1+S)
0x0132	WARTU	0	R/W	32-bit, 2'-complement	Set a value to gain calibrate the total voltage RMS.	
0x012D	WARTM	0	R/W	32-bit, 2'-complement	Set a value to gain calibrate the RMS value of various signal	

Register	Default	R/W	Format	Description	
				in Measurement Channel.	
0x0126	WBRTI	0	R/W	32-bit, 2'-complement	Set a value to gain calibrate the fundamental current RMS.
0x012B	WBRTU	0	R/W	32-bit, 2'-complement	Set a value to gain calibrate the fundamental voltage RMS.

Where,  
RMS is the value of RMS after calibration;  
RMS' is the value of RMS before calibration;  
S is the gain calibration of the RMS.  
The content of these registers must be verified.

**Table 9-16 Registers for Calibrating Active/Reactive Power (R/W)**

Register	Default	R/W	Format	Description	
0x012E	WAPT	0	R/W	32-bit 2'-complement	Set a value to gain calibrate the total active power.
0x0130	WAQT	0	R/W	32-bit 2'-complement	Set a value to gain calibrate the total reactive power.
0x012F	WWAPT	0	R/W	32-bit 2'-complement	Set a value to offset calibrate the total active power.
0x0131	WWAQT	0	R/W	32-bit 2'-complement	Set a value to offset calibrate the total reactive power.
0x0127	WBPT	0	R/W	32-bit 2'-complement	Set a value to gain calibrate the fundamental active power.
0x0129	WBQT	0	R/W	32-bit 2'-complement	Set a value to gain calibrate the fundamental reactive power.
0x0128	WWBPT	0	R/W	32-bit 2'-complement	Set a value to offset calibrate the fundamental active power.
0x012A	WWBQT	0	R/W	32-bit	Set a value to

The actual value in decimal form is acquired by dividing the register reading by  $2^{31}$ .  
The value of power before and after calibration have a relationship as follows:  
 $P = P' \times (1 + S) + C$   
Where,  
P is the active or reactive power after calibration;  
P' is the active or reactive power before calibration;  
S is the gain calibration of the power;  
C is the offset calibration of the power.  
The content of these registers must be verified.

Register		Default	R/W	Format	Description
				2'-complement	offset calibrate the fundamental reactive power.

**Table 9-17 Threshold Register**

Register		Default	R/W	Format	Description
0x0181	EGYTH	0	R/W	32-bit, 2'-complement	Set a threshold for energy-to-pulse conversion. The content of this register must be verified.
0x0182	CTH	0	R/W	32-bit, 2'-complement	Set a threshold for no-load detection. The content of this register must be verified.
0x0134	IDETTH	0	R/W	32-bit 2'-complement	Set a threshold for current detection. When the current detection is enabled, the current detection circuit will compare the absolute value of the instantaneous current signal to the preset current detection threshold in this register. When some continuous samples of the current signal are higher than the threshold, it means a current signal is caught. The content of this register must be verified.

**Table 9-18 Register for Bandpass Filter Coefficient Configuration (0x0125, BPF PARA, R/W)**

Register		Default	R/W	Format	Description
0x0125	BPF PARA	0	R/W	32-bit 2'-complement	Set the coefficient of the bandpass filter. Generally, it is set to "0x811D2BA7" for the best performance. This coefficient and the bits to be shift in the bandpass filter have effects on filter response time, the sensitivity to the frequency deviation, and the suppression on the harmonics and noise. The content of this register must be verified.

## 9.6. Checksum Register

**Table 9-19 Checksum Register (0x0133, CKSUM, R/W)**

Register		Default	R/W	Format	Description
0x0133	CKSUM	0	R/W	32-bit 2'-complement	Add the value of this register and other 24 registers (Including metering control registers, analog control registers, and registers for calibration, see "

Register		Default	R/W	Format	Description
					<p>Interrupt” for details) to compute the checksum for configuration verification to ensure the configuration of all the registers are in the desired states. If the sum is <b>“0xFFFFFFFF”</b>, the verification will pass.</p> <p>This register should be set to the difference of <b>“0xFFFFFFFF”</b> and the sum of the other 24 registers.</p>

Vangotech

# 10. Outline Dimensions

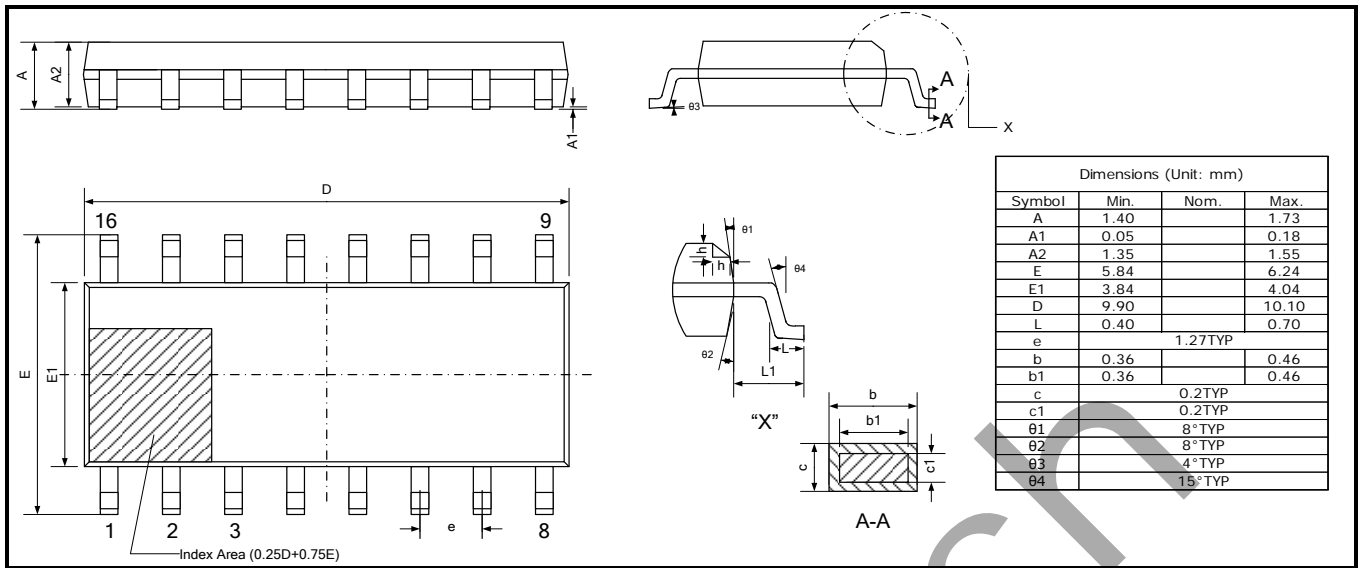

Vangotech